

# **FARAD<sup>®</sup> BARS**

made in italy

## **BS 132**

NISSAN PULSAR 2014>

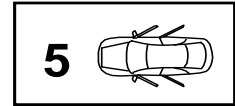

**I** Istruzioni di montaggio

**F** Instructions de montage

**PL** Instrukcja montażu

**D** Einbauanleitung

**GB** Fitting instructions

**E** Instrucciones de montaje

**NL** Inbouwhandleiding

**SWE** Montageanvisnin

# KIT BS

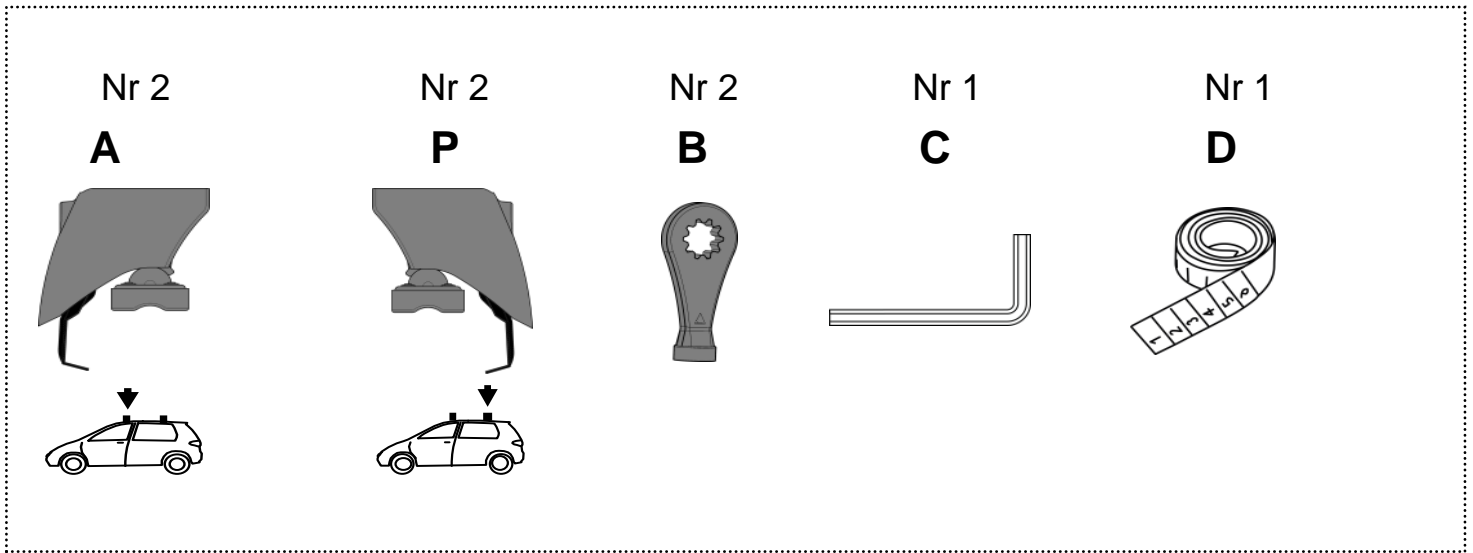

# KIT ALU

+

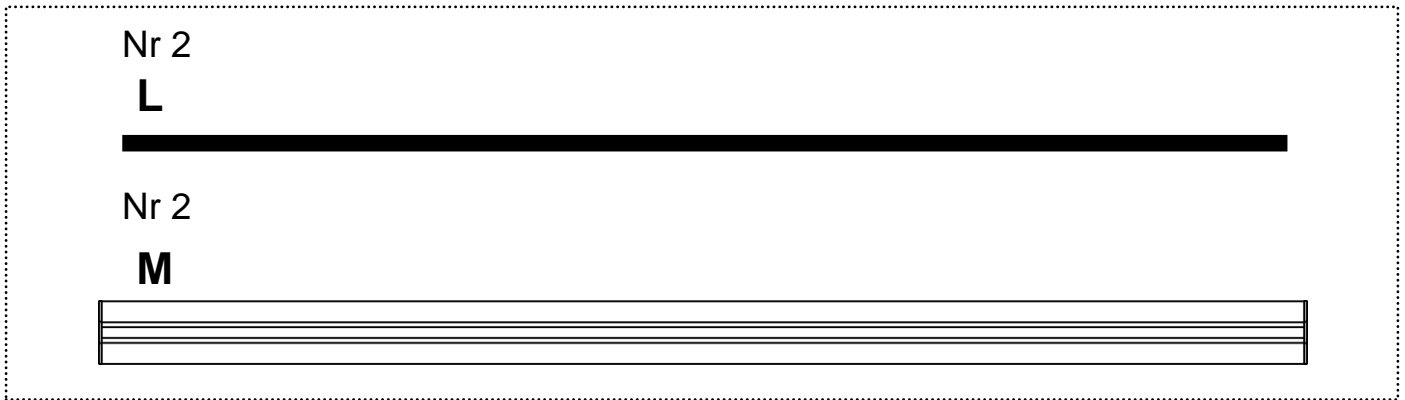

=

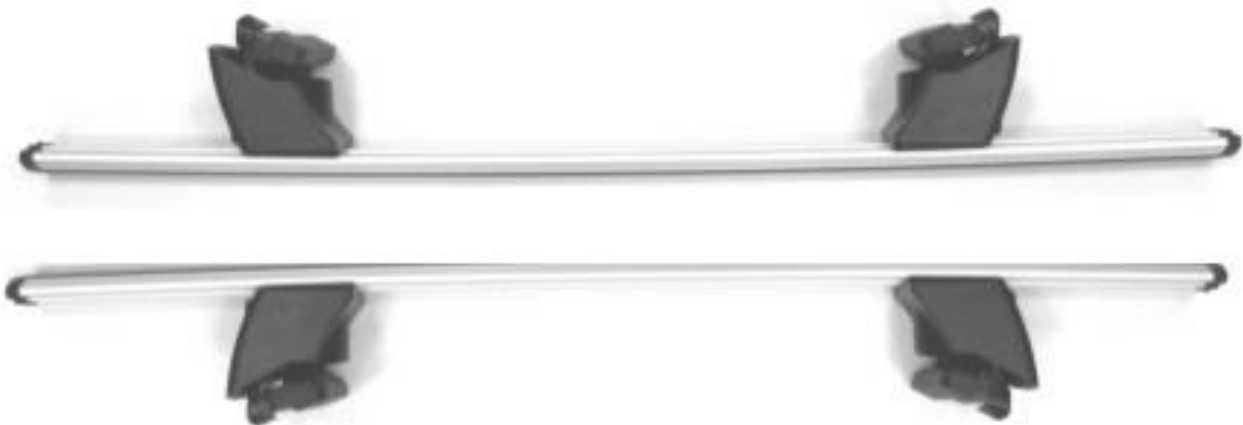

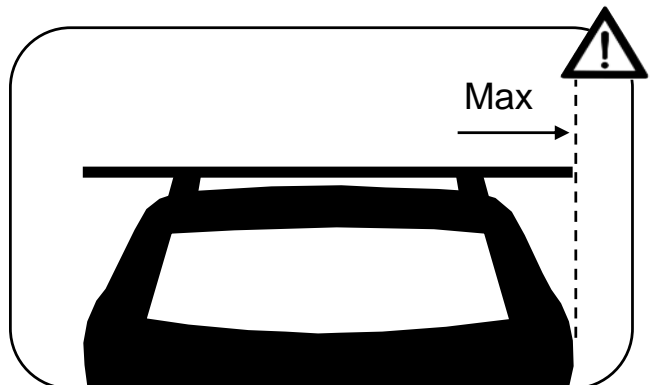
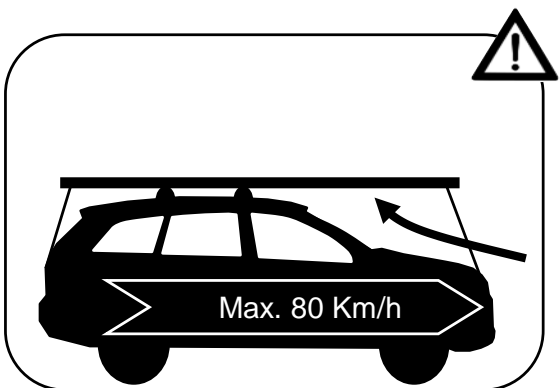
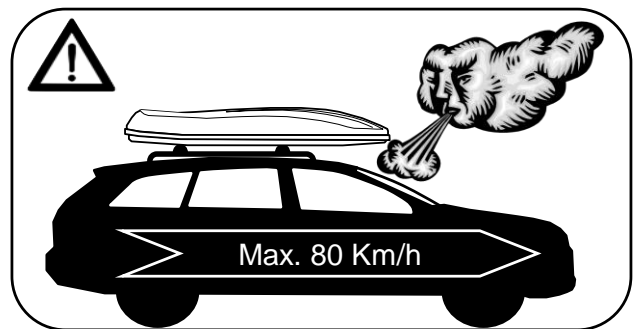
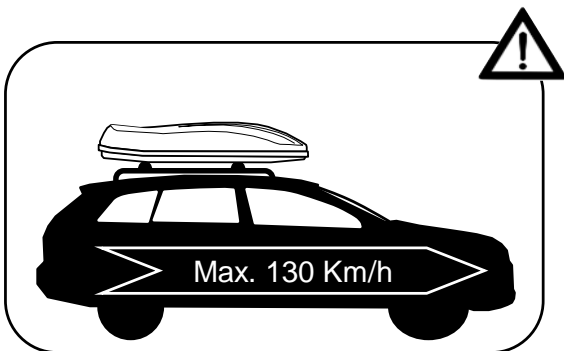
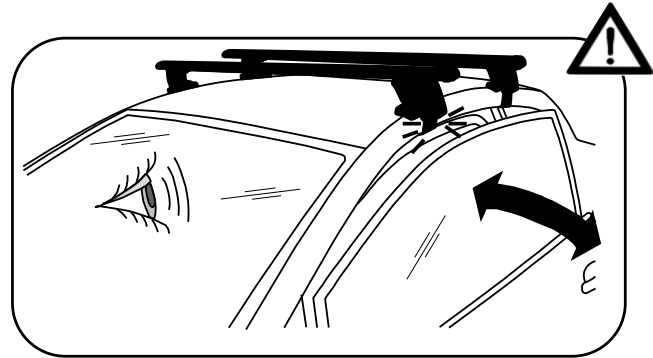
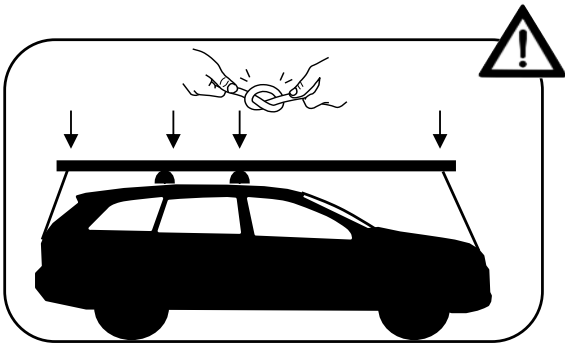
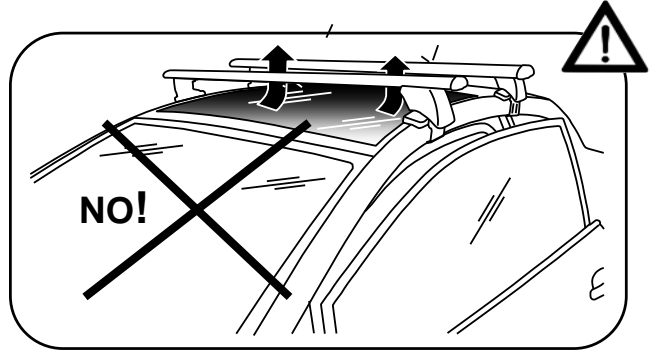
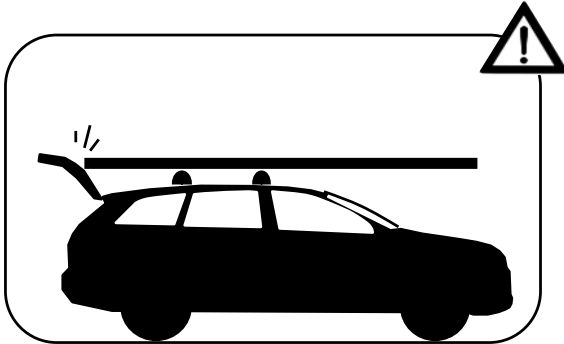
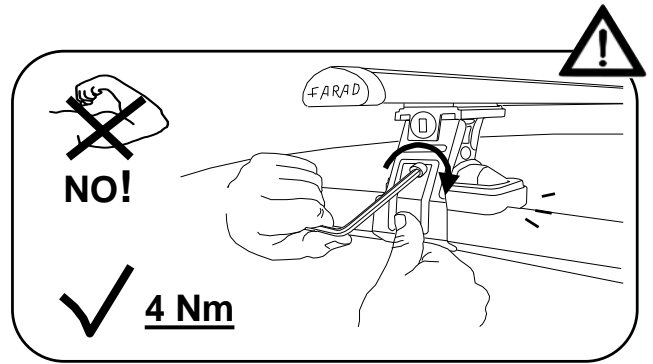
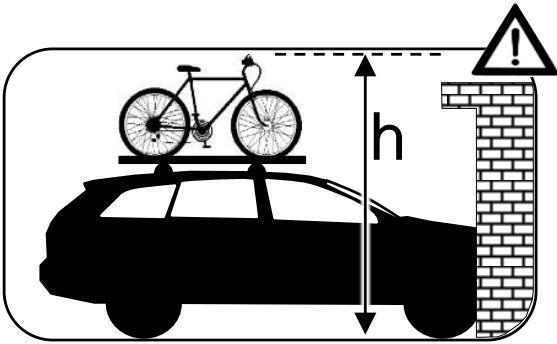

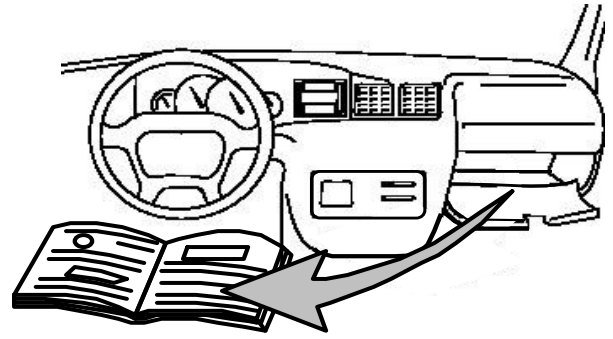
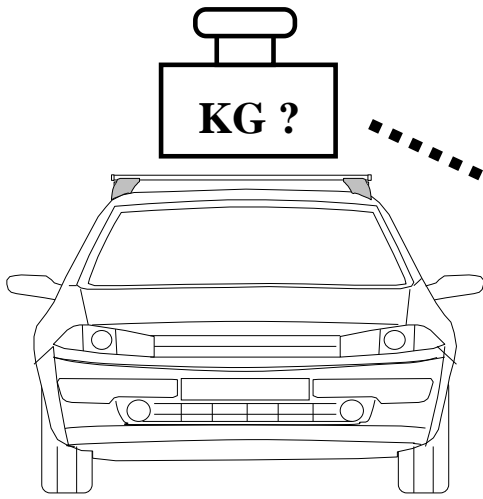

- I Controllare carico del tetto sul manuale dell'auto
- PL Sprawdź ładowność dachu w instrukcji
- GB Check roof load capacity in car instruction
- NL check de handleiding belasting van het dak van de auto
- F vérifier le chargement manuel du toit de la voiture
- D überprüfen Sie die manuelle Beladung der Autodach
- E comprobar la carga manual del techo del coche
- SWE kontrollera manuell inläggning på taket av bilen

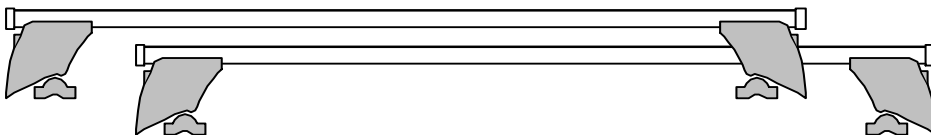
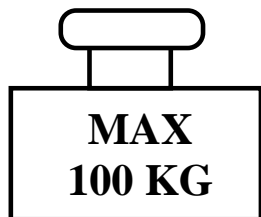
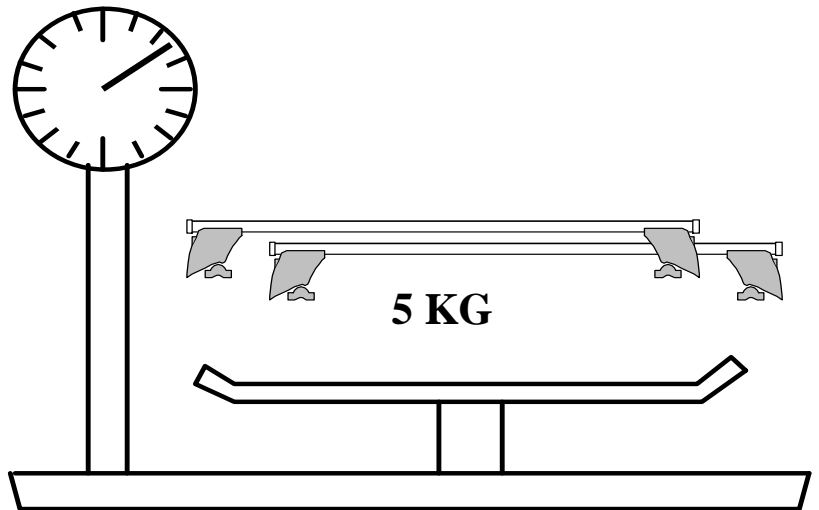

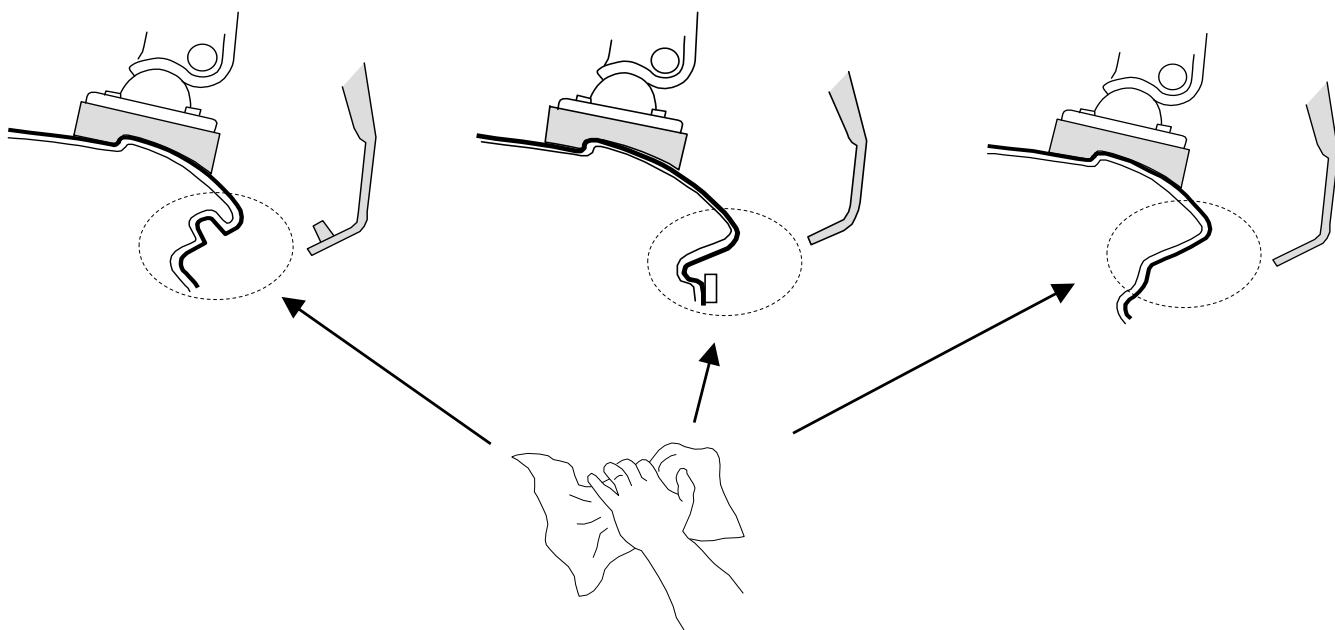
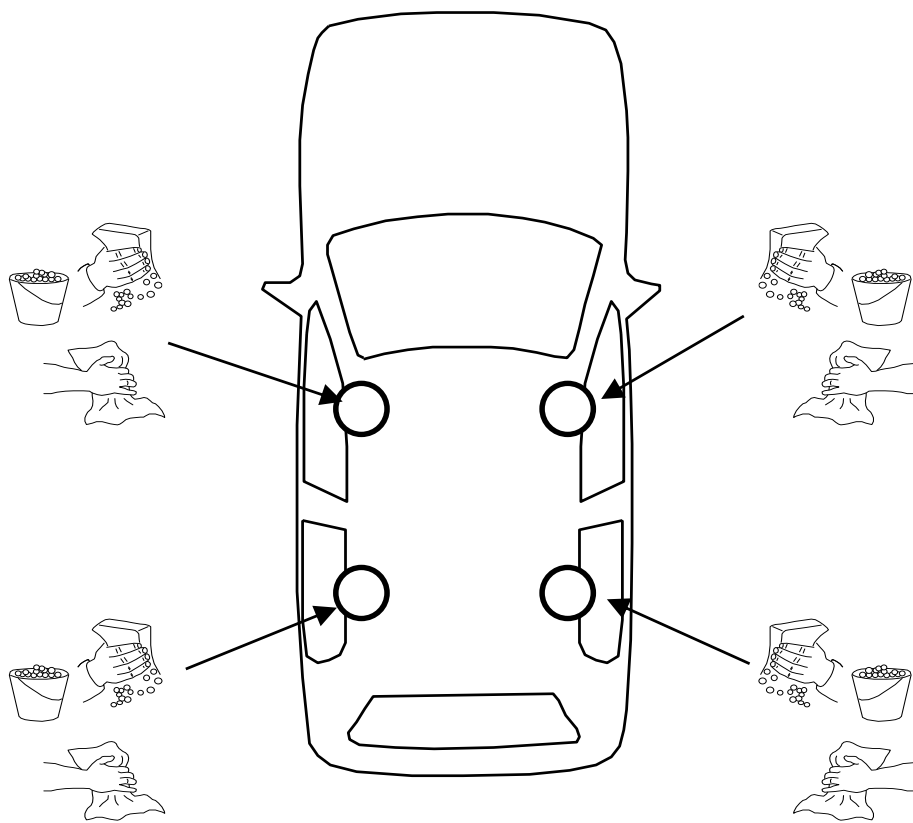

I Montaggio Barra Anteriore

F Fixation Barre Avant

PL Montaż Bagażnika Bazowego Tylnego

GB Fitting Front Roof Bar

D Montage Vorderes Dachträgers

NL Montage Voorste Dakdrager

SW Montering Av Främre Lasthållaren

E Fijación Barra Frontal

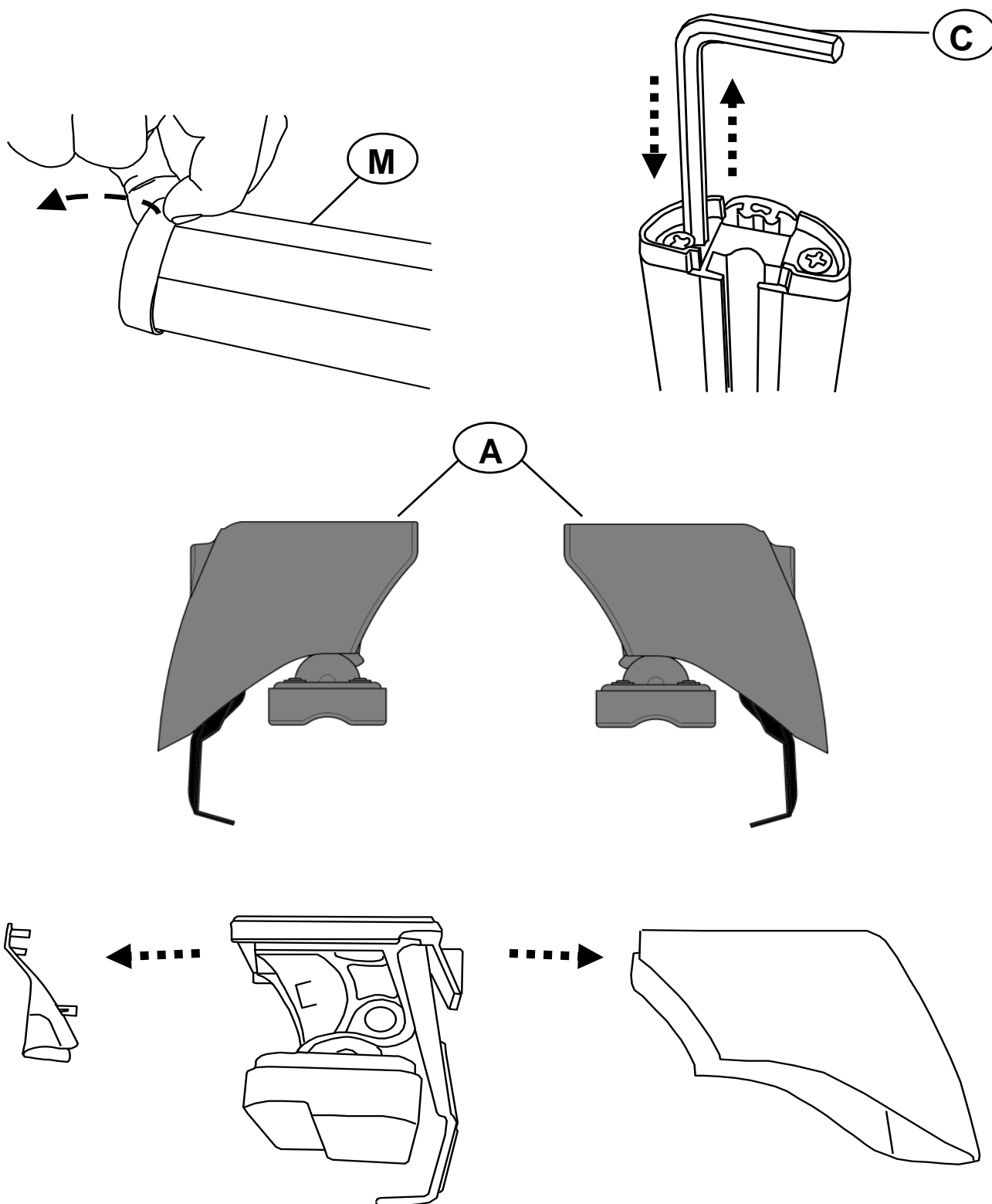



M

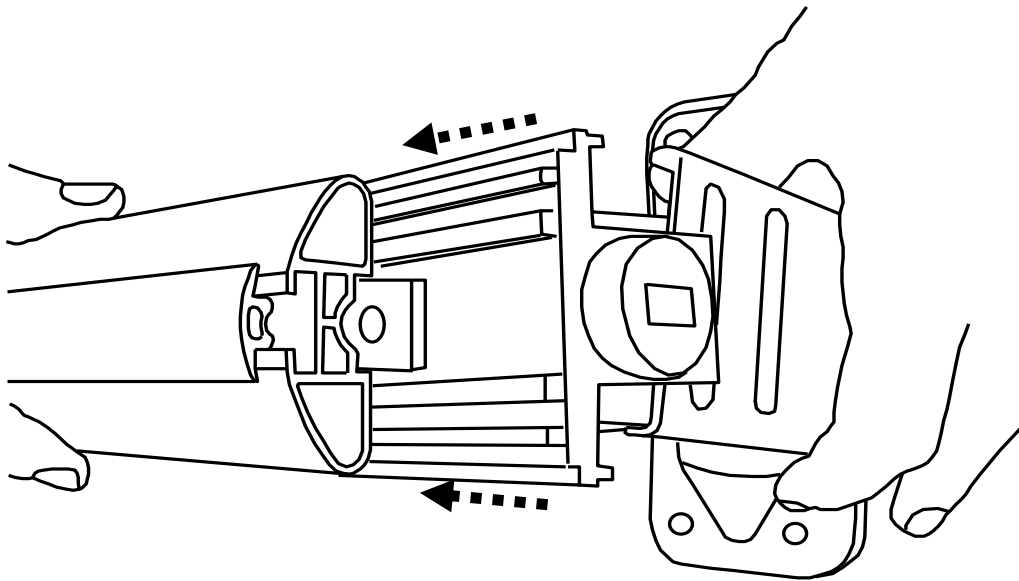
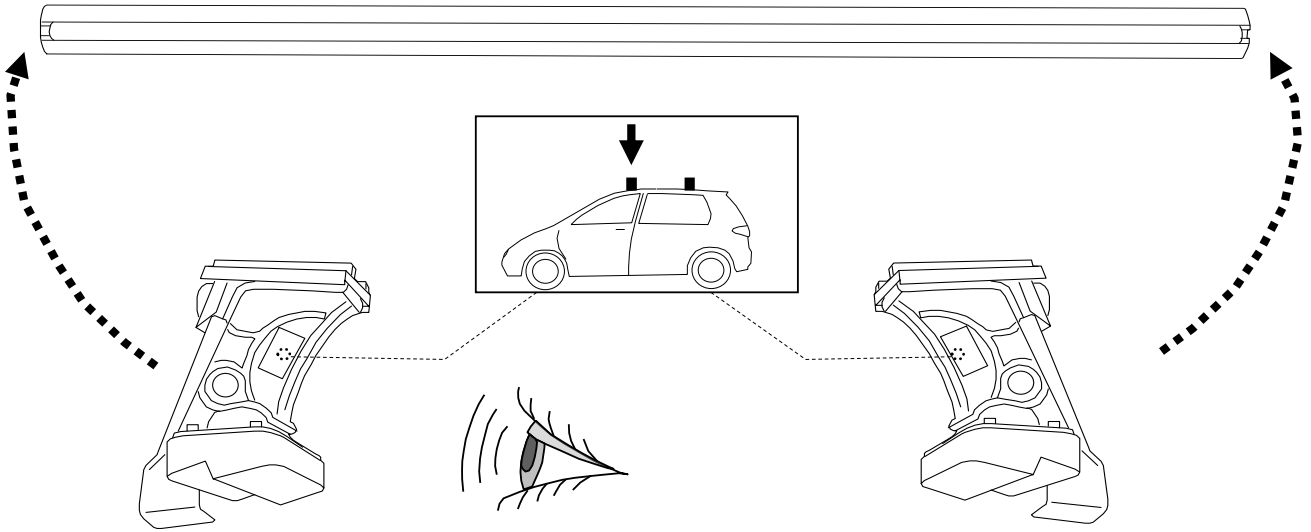

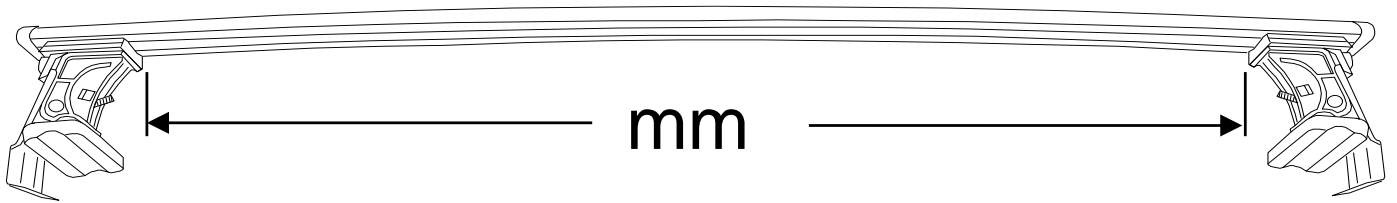

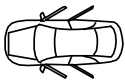
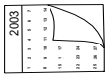
			<b>R</b>	<b>mm</b>
<b>NISSAN</b>	<b>PULSAR</b>	<b>5</b>	<b>R= 32</b>	<b>1025</b>

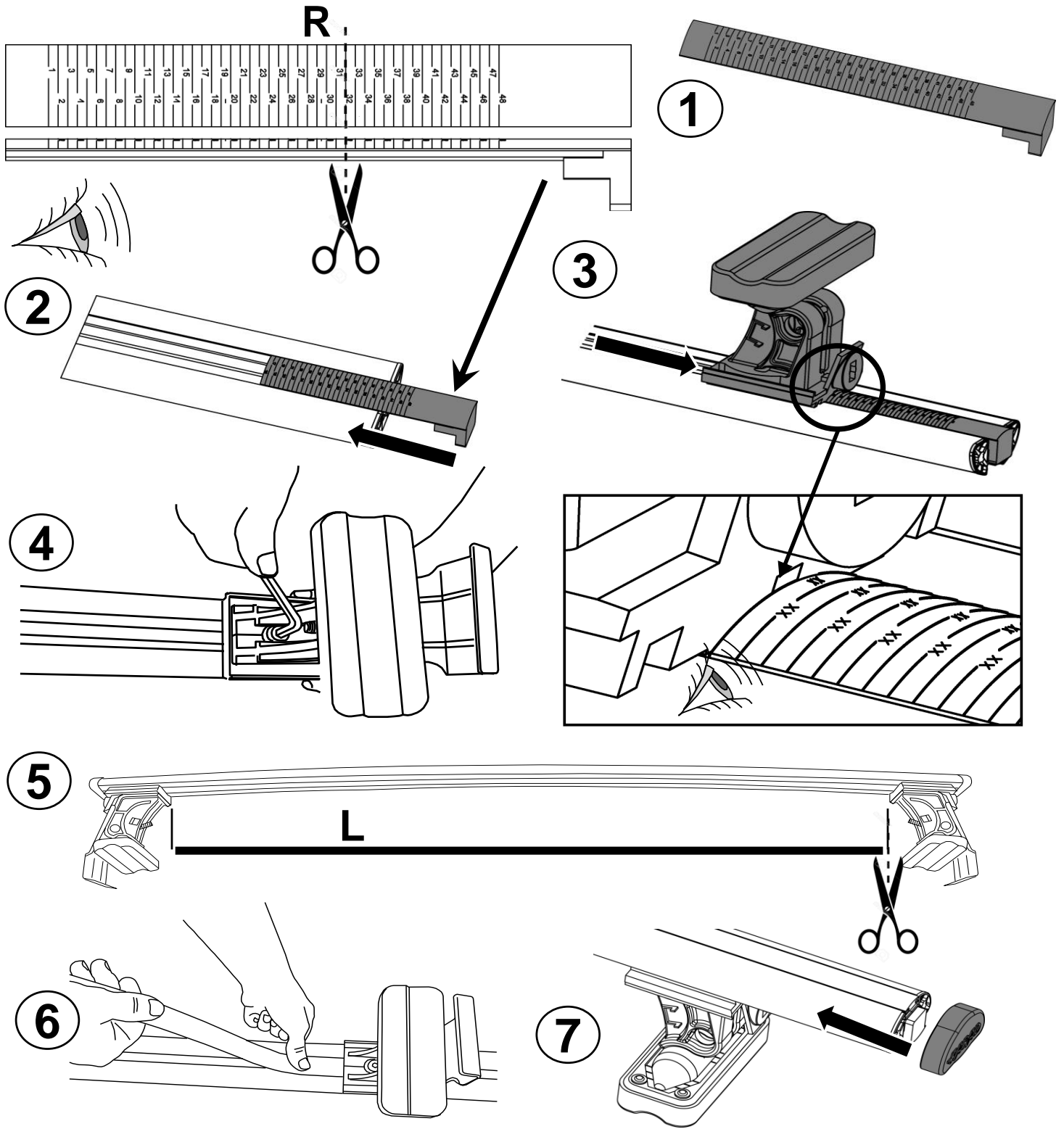



<b>REV 000</b>	<b>24/11/2014</b>	<b>8 / 20</b>
----------------	-------------------	---------------

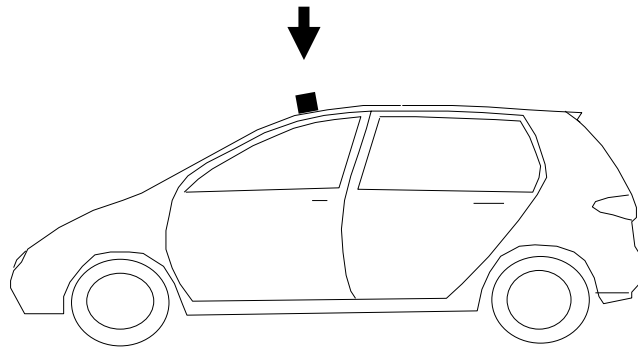

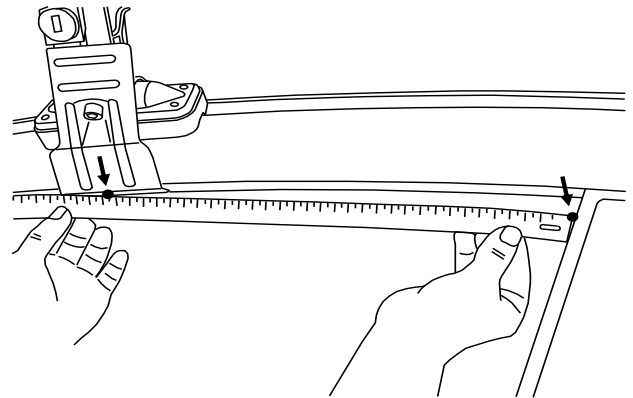
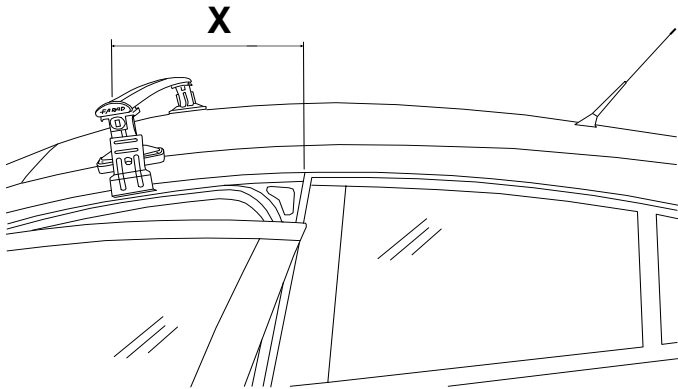

**D**

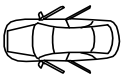
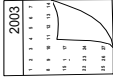

			<b>X</b>
<b>NISSAN</b>	<b>PULSAR</b>	<b>5</b>	<b>X = 200</b>

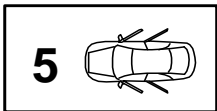

✓ **4 Nm**

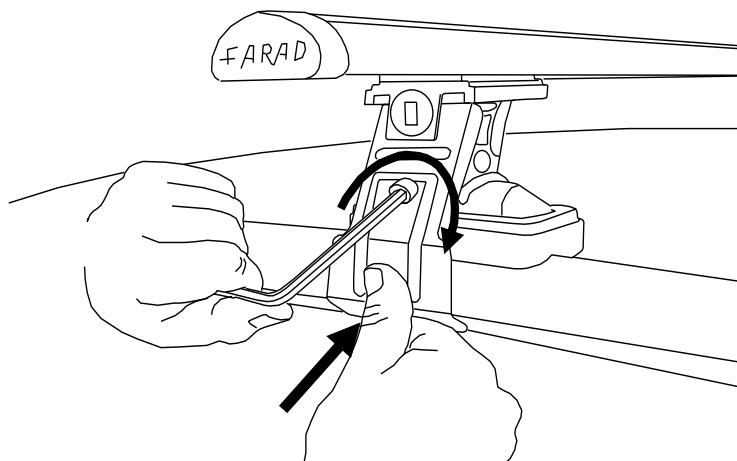

**C**

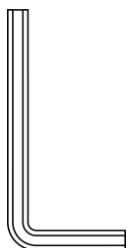

<b>REV 000</b>	<b>24/11/2014</b>	<b>9 / 20</b>
----------------	-------------------	---------------

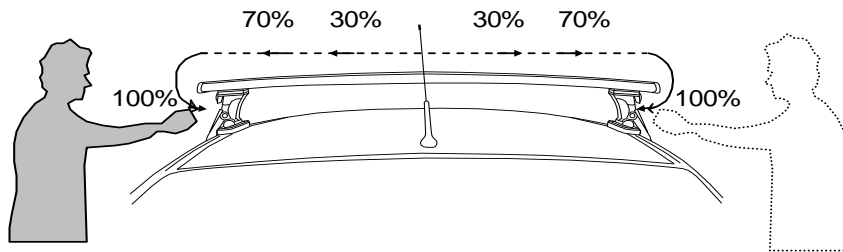

I Alternare il fissaggio delle viti  
PL Śruby dokręcaj naprzemiennie  
GB Tighten alternately  
NL Afwisselend aan de linker- en de

F Serrer alternativement chaque côté  
D Die Schrauben abwechselnd anziehen  
E Apretar alternativamente  
SWE Dra åt växelvis

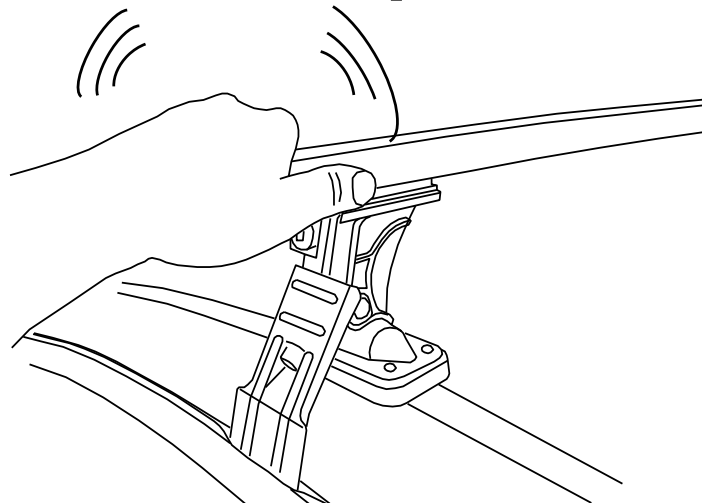
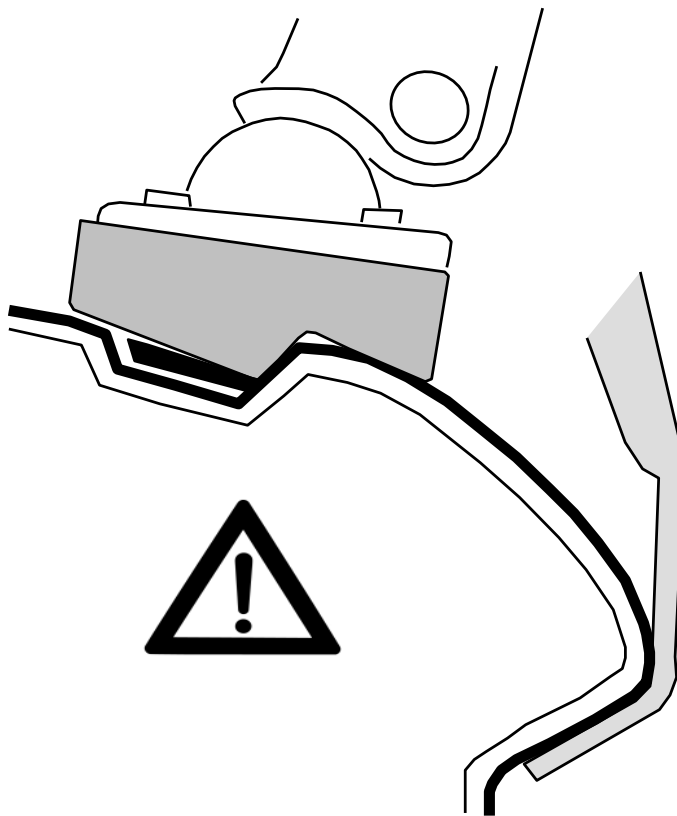
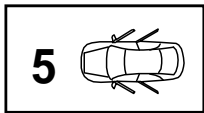

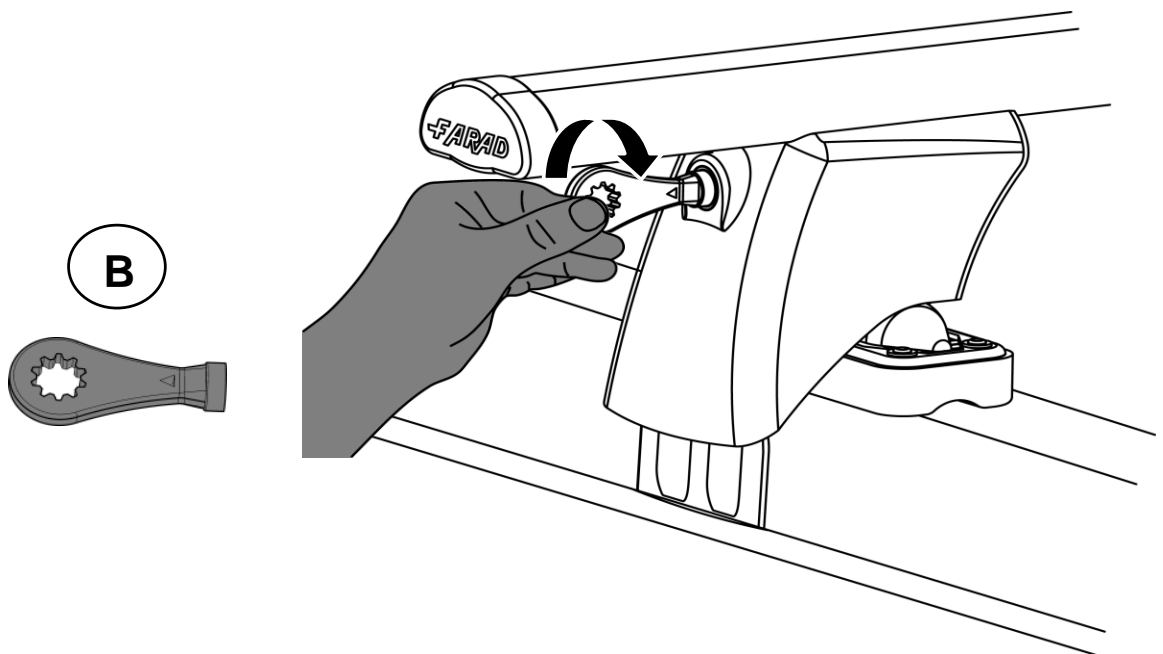
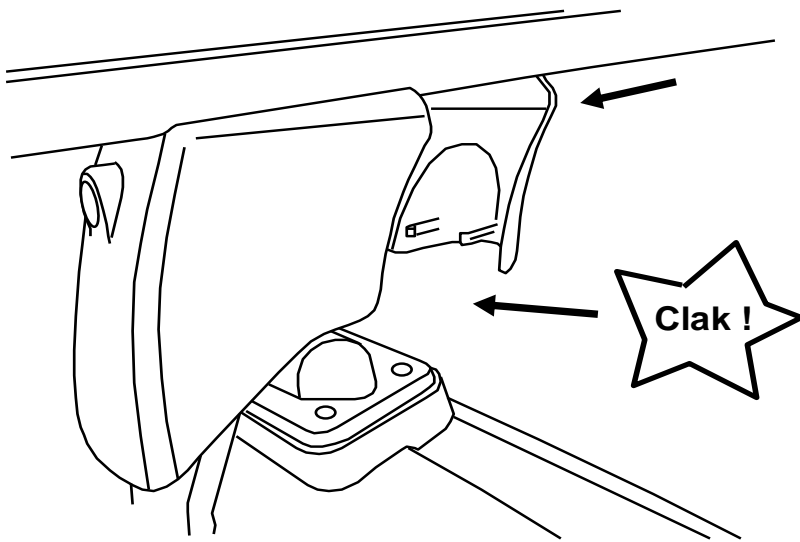
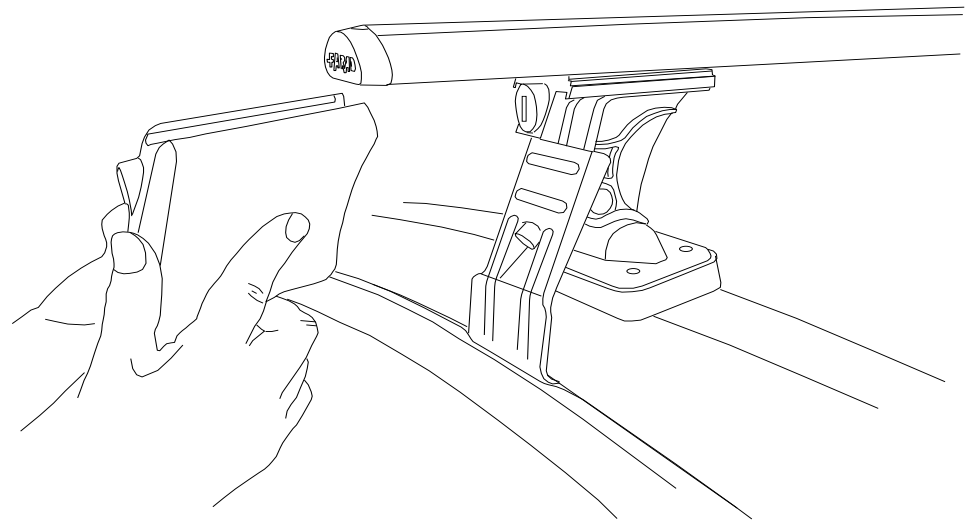

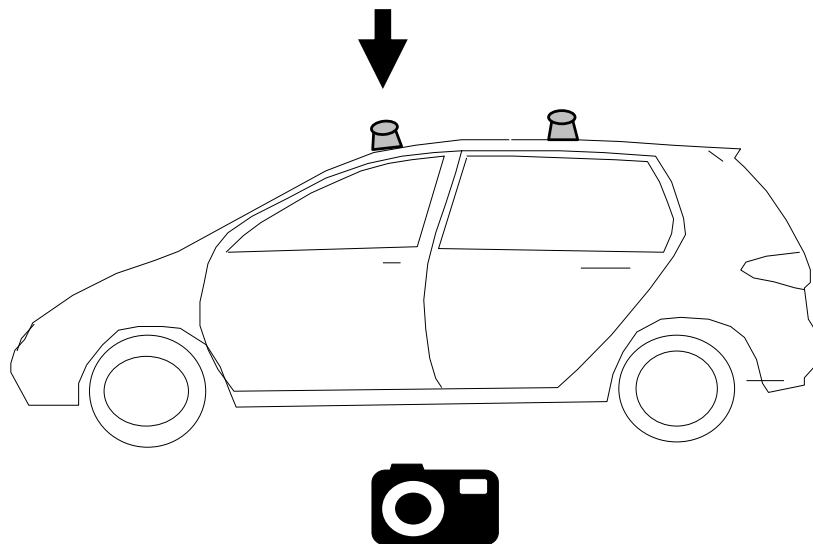

- I** CONTROLLARE PERIODICAMENTE IL FISSAGGIO DELLE VITI
- PL** OKRESOWO SPRAWDZAJ MOCOWANIE ŚRUB
- GB** CHECK THE SCREW FASTENING PERIODICALLY
- D** REGELMÄSSIG ÜBERPRÜFEN DIE BEFESTIGUNG DER SCHRAUBEN
- SWE** REGELBUNDET KONTROLLERA OM FASTSTÄLLANDE AV SKRUVARNA
- F** VERIFIEZ LA FIXATION DES VIS PERIODIQUEMENT

I **Montaggio barra posteriore**

F **Fixation Barre Arriere**

PL **Montaż Bagażnika Bazowego Przedniego**

GB **Fitting Rear Roof Bar**

SWE **Montering Främre Lasthållaren**

E **Fijación Barra Trasera**

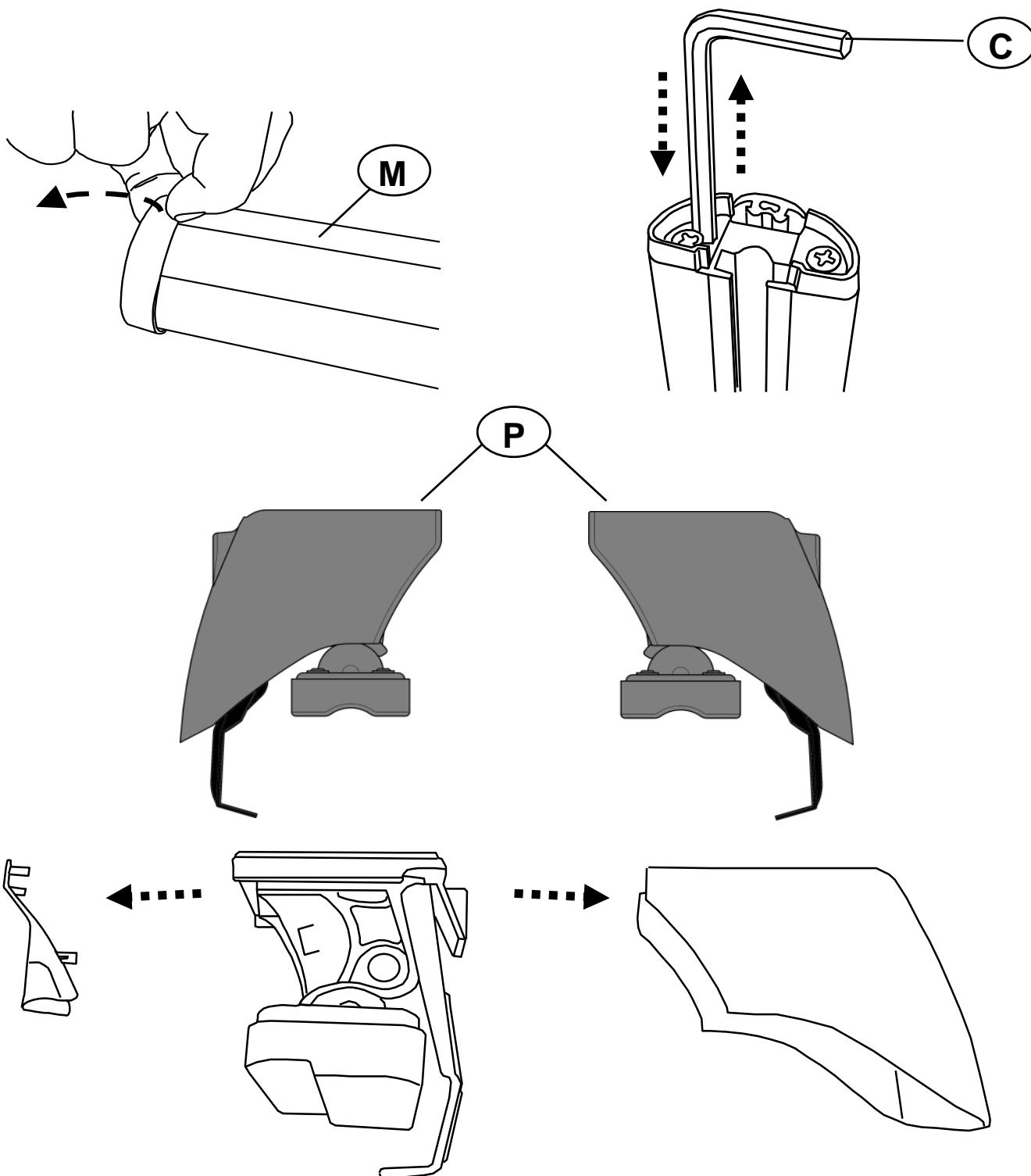

NL **Montage Achterste Dakdrager**

D **Montage Heckdachträgers**

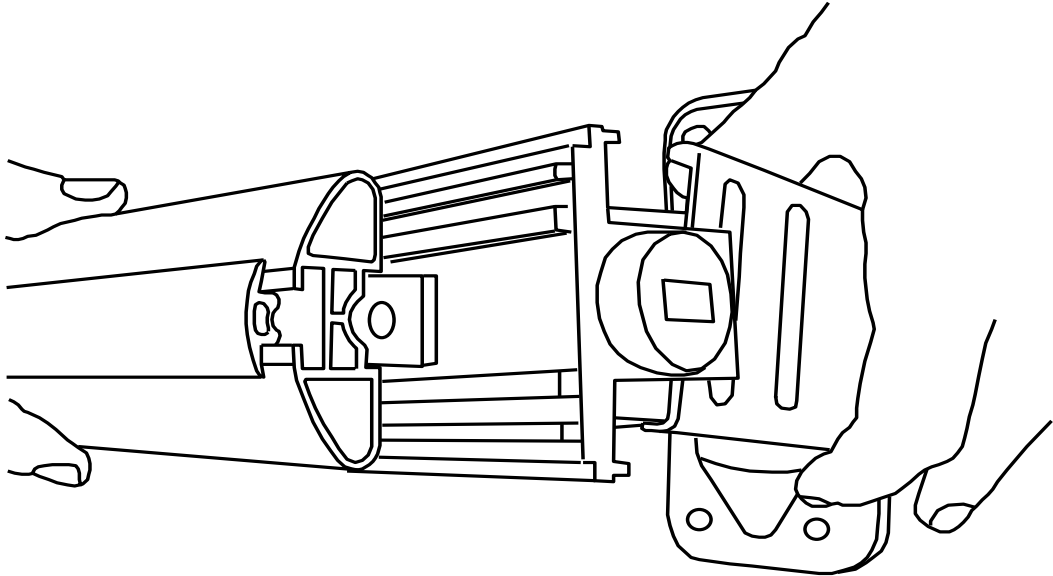
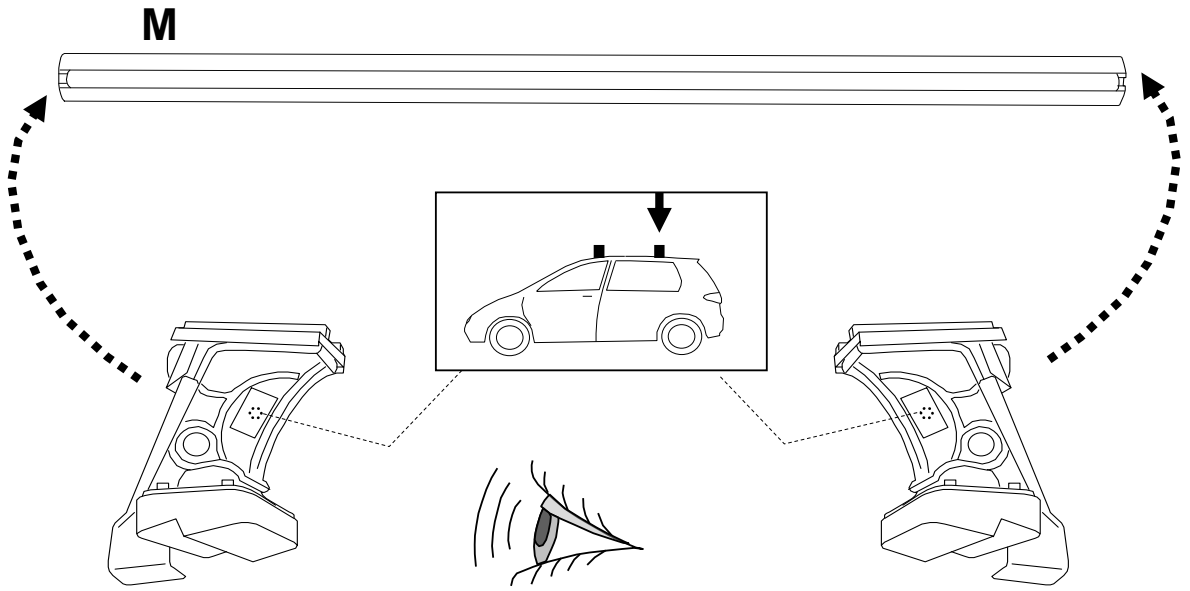

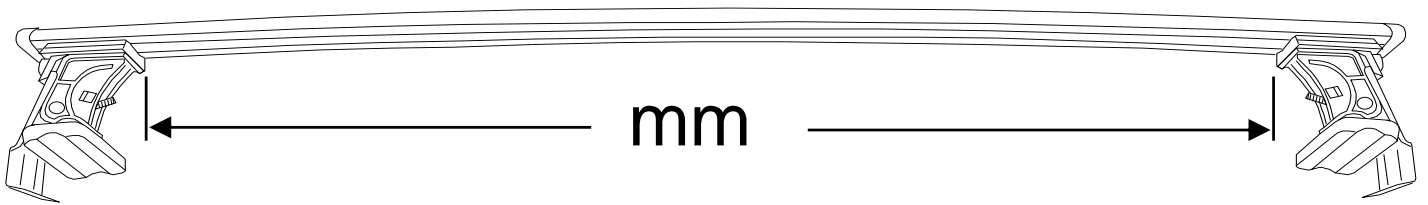



			<b>R</b>	<b>mm</b>
<b>NISSAN</b>	<b>PULSAR</b>	<b>5</b>	<b>R= 21</b>	<b>970</b>

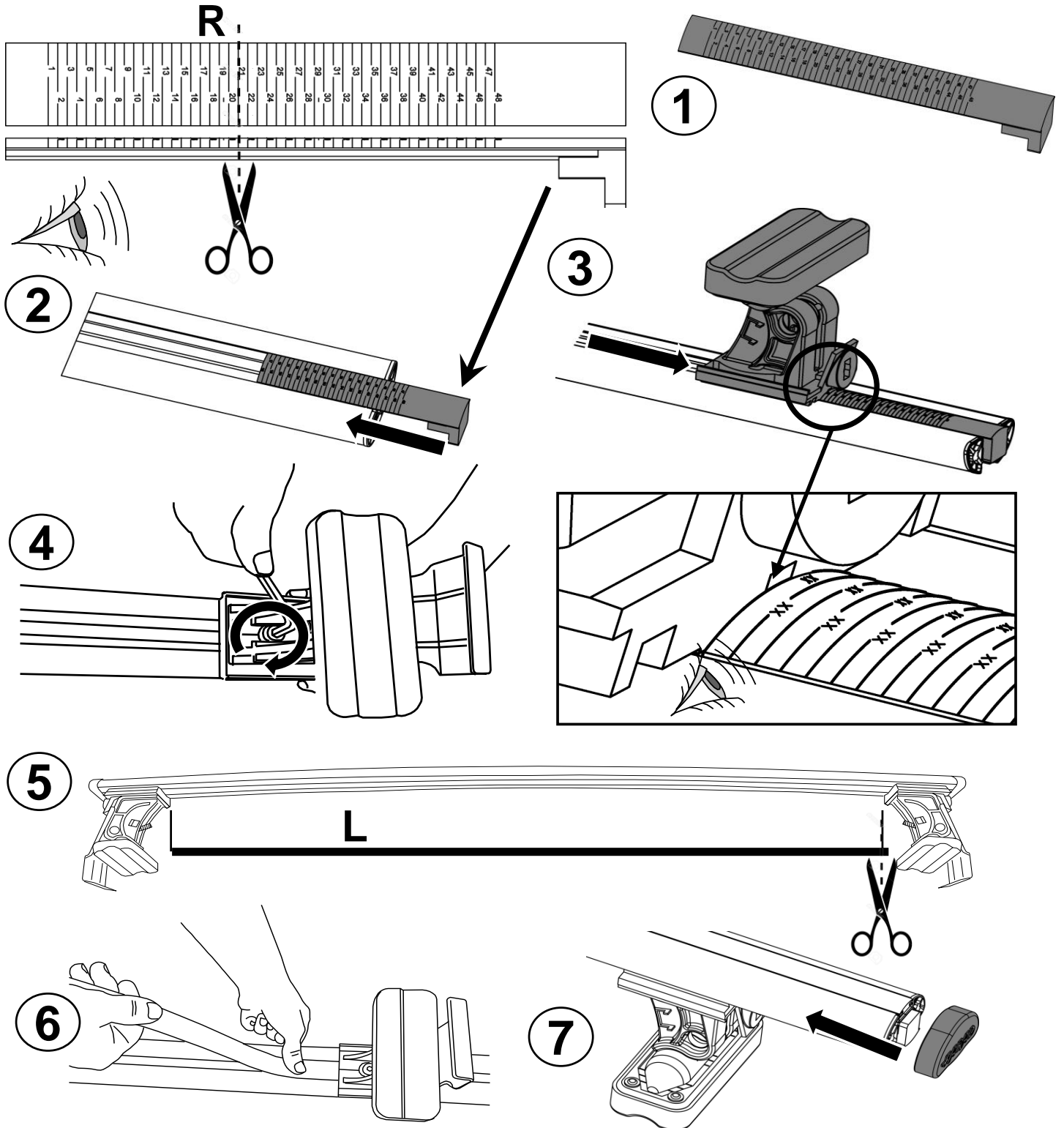

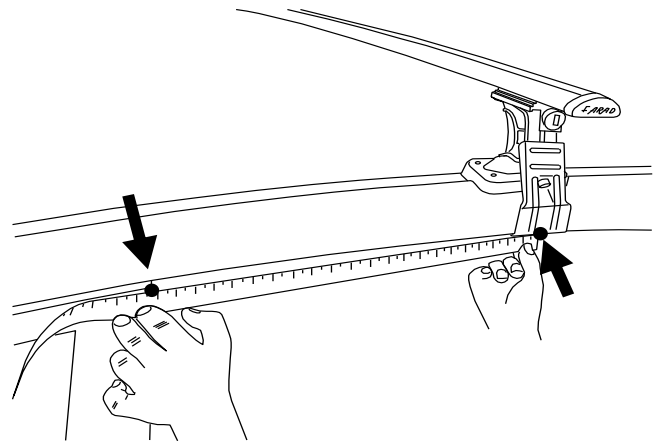
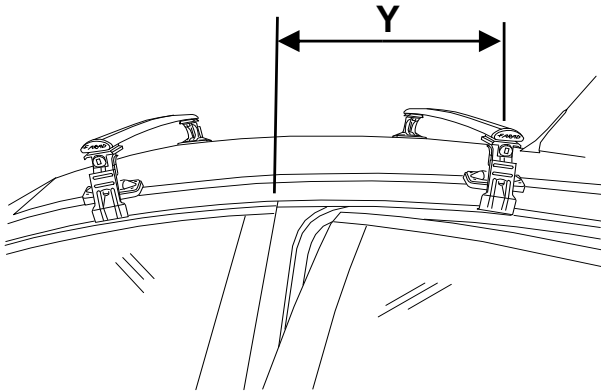
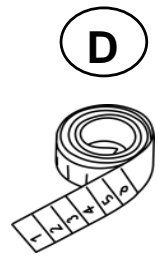
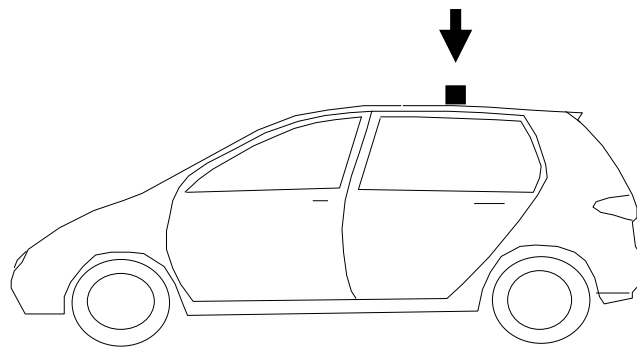

				<b>Y</b>
<b>NISSAN</b>	<b>PULSAR</b>	<b>5</b>	<b>2014 &gt;</b>	<b>Y = 400</b>

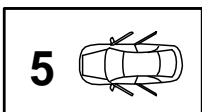

✓ **4 Nm**

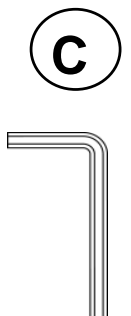
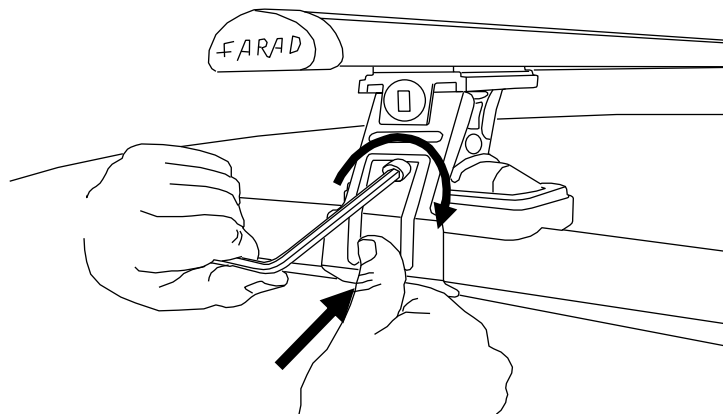



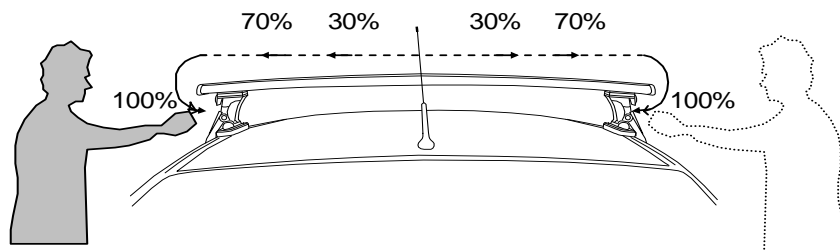

I Alternare il fissaggio delle viti  
PL Śruby dokręcaj naprzemiennie  
GB Tighten alternately  
NL Afwisselend aan de linker- en  
de rechterkant aandraaien

F Serrer alternativement chaque côté  
D Die Schrauben abwechselnd anziehen  
E Apretar alternativamente  
SWE Dra åt växelvis

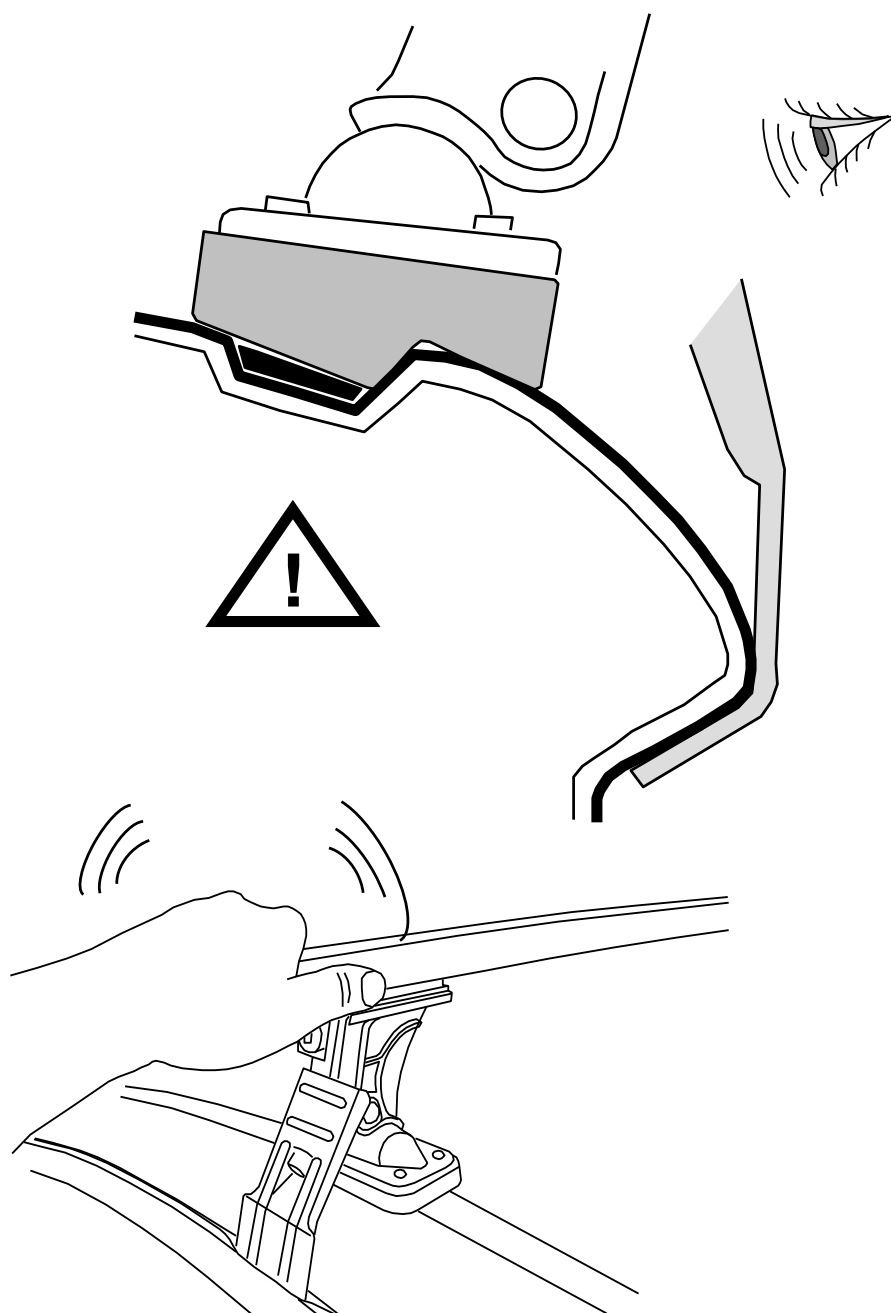
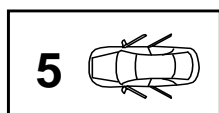

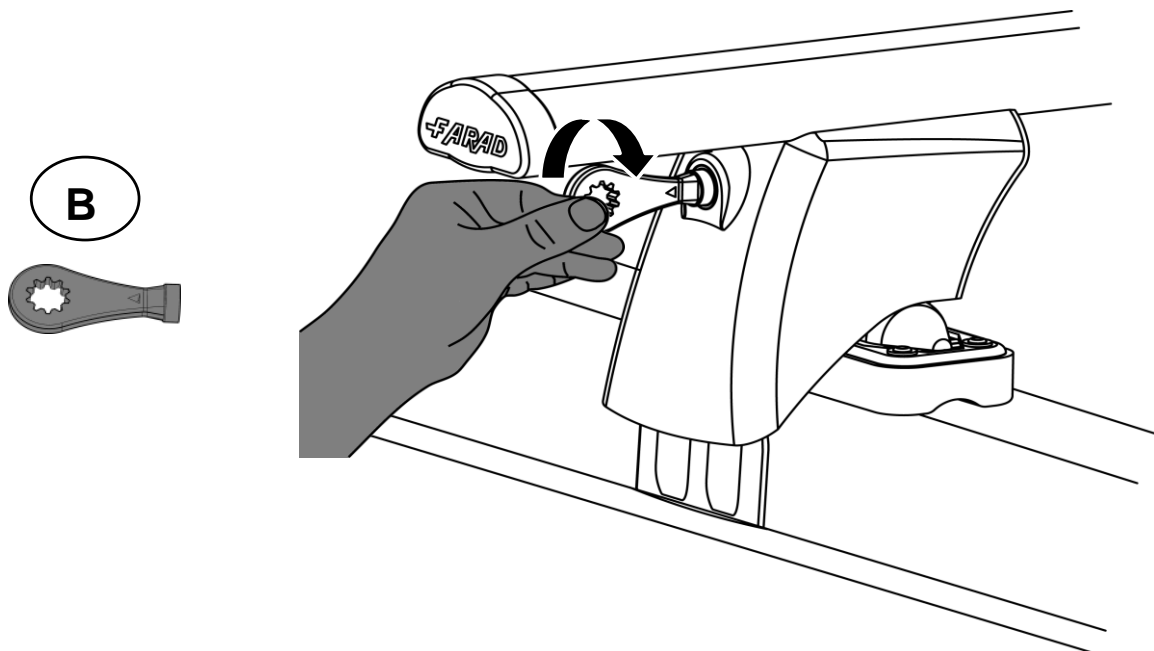
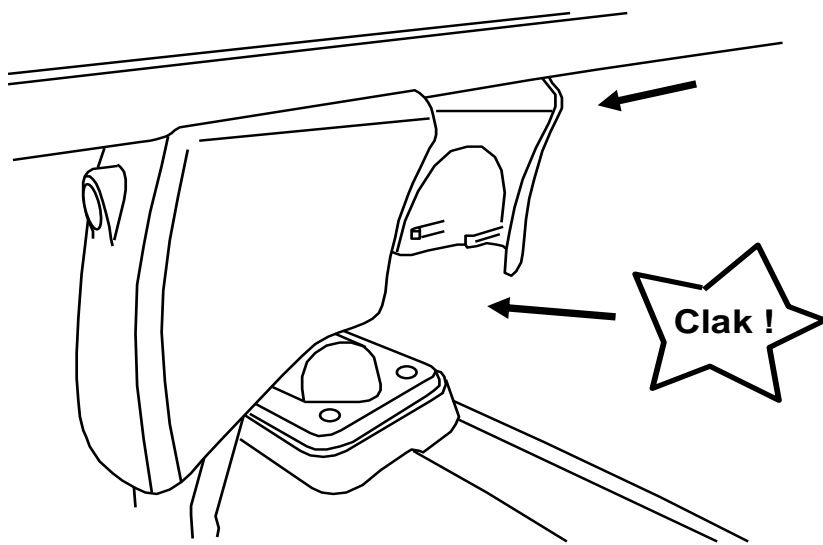
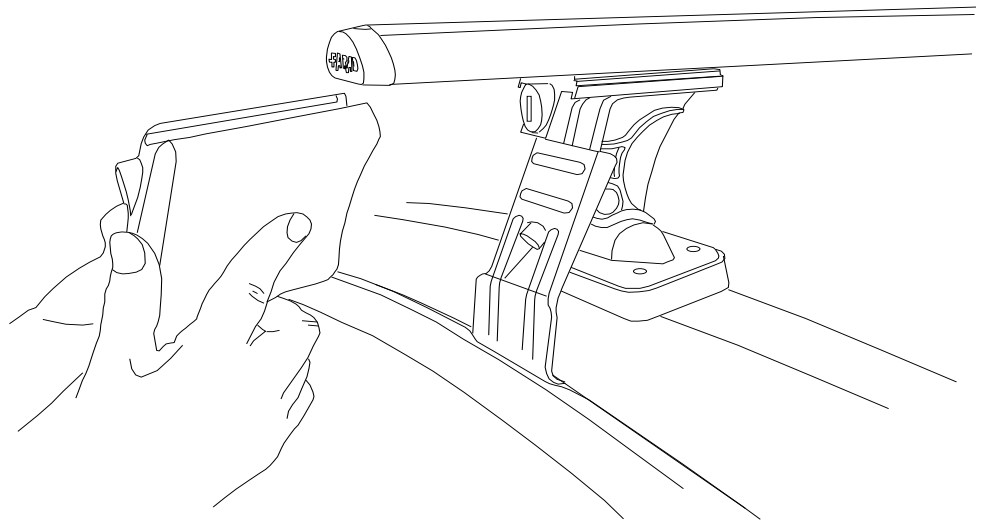

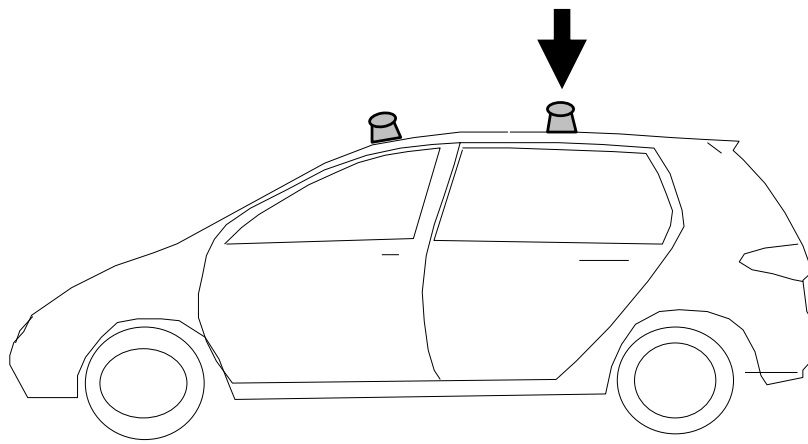

- I** CONTROLLARE PERIODICAMENTE IL FISSAGGIO DELLE VITI
- PL** OKRESOWO SPRAWDZAJ MOCOWANIE ŚRUB
- GB** CHECK THE SCREW FASTENING PERIODICALLY
- D** REGELMÄSSIG ÜBERPRÜFEN DIE BEFESTIGUNG DER SCHRAUBEN
- SWE** REGELBUNDET KONTROLLERA OM FASTSTÄLLANDE AV SKRUVARNA
- F** VERIFIEZ LA FIXATION DES VIS PERIODIQUEMENT

# RICAMBI - SPARE PARTS



PIEDE GIREVOLE  
90341 / 2

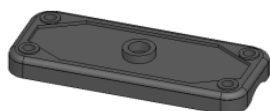

PIEDE FISSO  
90341 / 15

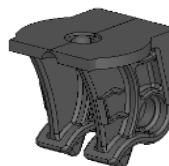

SUPPORTO CENTRALE  
90341 / 1

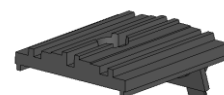

SUPPORTO BARRA  
90341 / 5



SOTTO PIEDE SP01  
90341 / 3



SOTTO PIEDE SP03  
90341 / 16



SOTTO PIEDE SP04  
90341 / 13



SOTTO PIEDE SP07  
90341 / 11



SOTTO PIEDE SP08  
90341/14



SOTTO PIEDE SP10  
90341 / 12



SOTTO PIEDE SP12  
90341 / 1



CHIAVE ESAGONALE 6  
9331 / 148

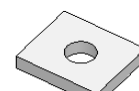

PIASTRINA  
90341 / 21



DISTANZIALE  
90341 / 20



NOTTOLINO + N° COMB.  
90341 / 6



SOTTOTAPPO  
90241 / 9



TAPPO BARRA  
90241 / 6

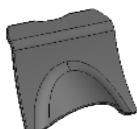

INVOLUCRO POST.  
90341 / 9

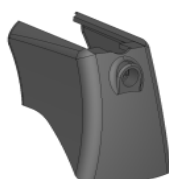

INVOLUCRO ANTERIORE  
90341 / 8



CHIAVE + N° COMB  
90341 / 7



PALETTA  
90341 / 4



BARRA ALLUMINIO  
90241 / 7



GUARNIZIONE BARRA  
90241 / 8



RIGA CARTA  
90341 / 19

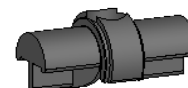

PERNO  
90241 / 15

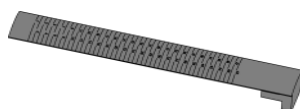

GUARNIZIONE  
NUMERICA  
91141 / 14

**FARAD**<sup>®</sup>  
made in italy

tel. 011 9713719 - n° verde 800984229  
[www.faradworld.com](http://www.faradworld.com)