

FARAD[®] BARS

made in italy

BS 147

OPEL KARL 2017 >

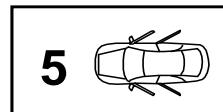

I	Istruzioni di montaggio	F	Instructions de montage
PL	Instrukcja montażu	D	Einbauanleitung
GB	Fitting instructions	E	Instrucciones de montaje
NL	Inbouwhandleiding	SWE	Montageanvisnin

KIT BS

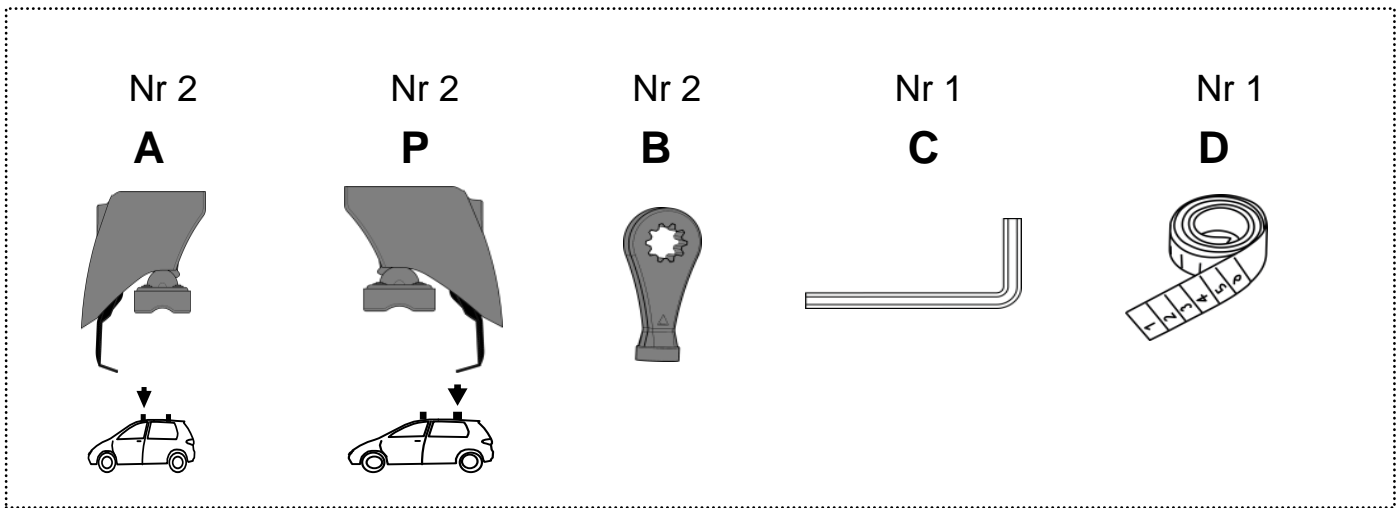

+

KIT ALU

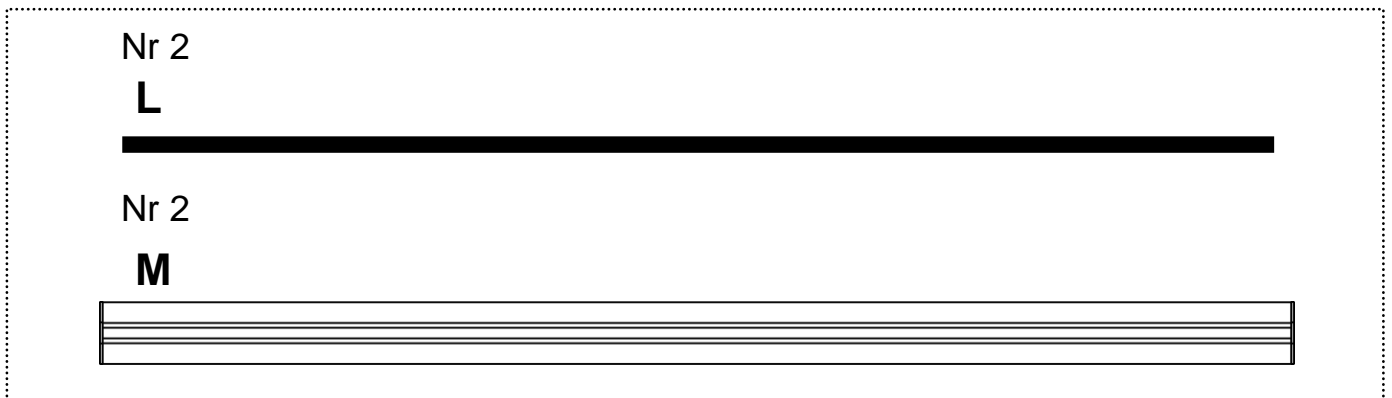

=

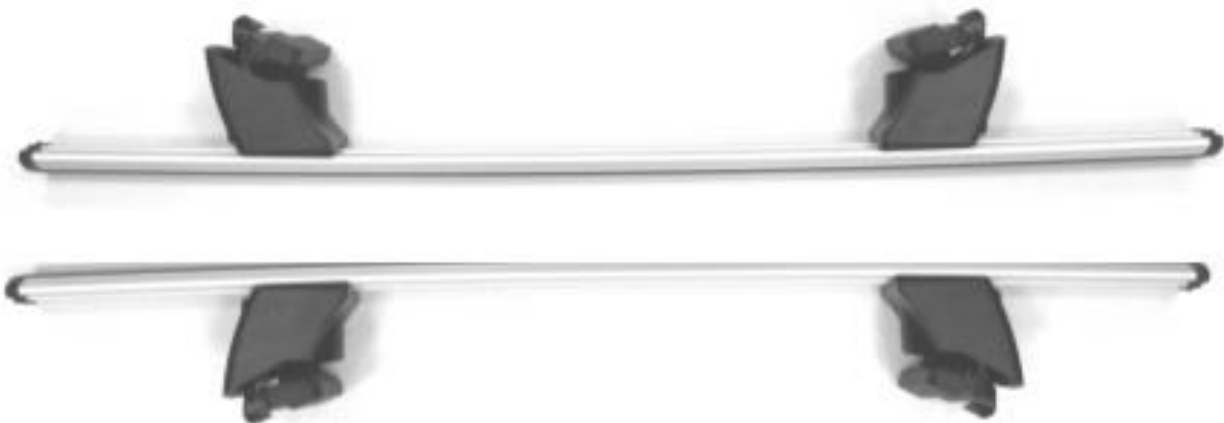

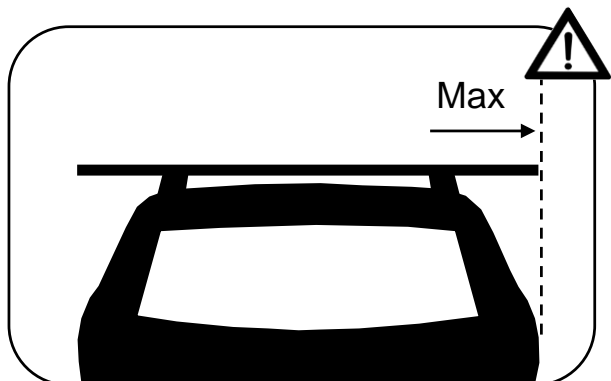
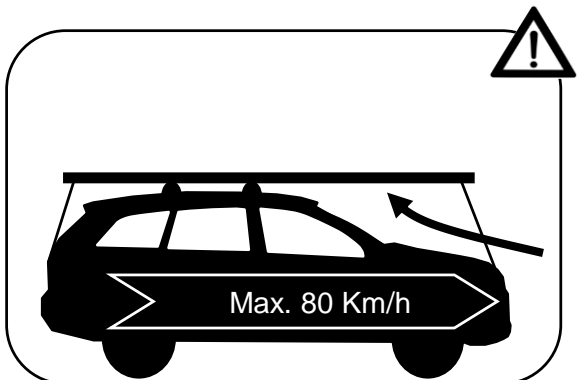
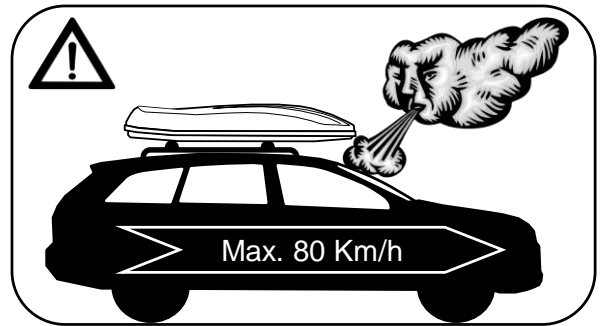
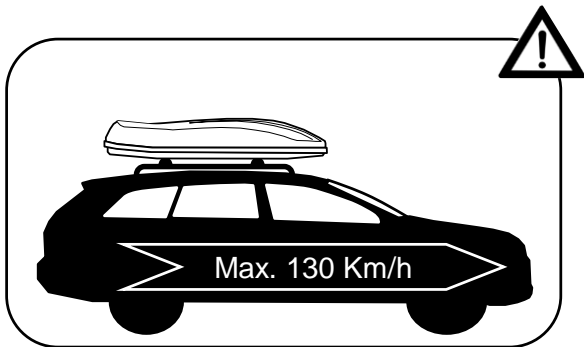
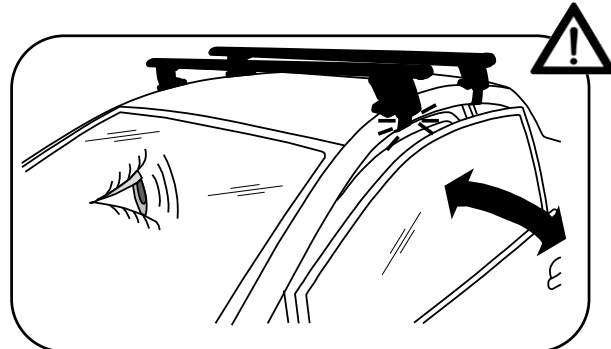
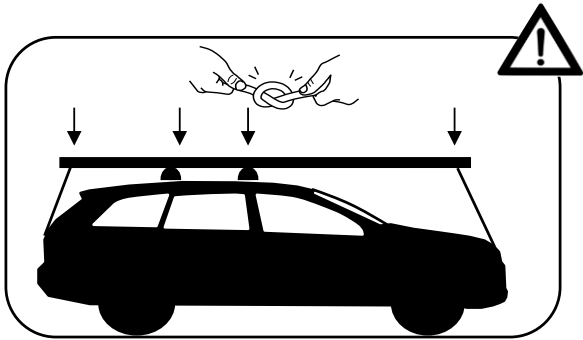
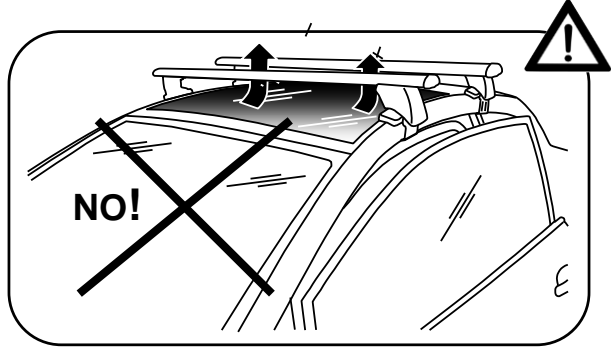
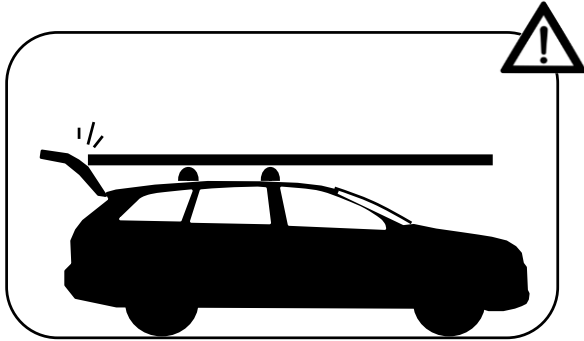
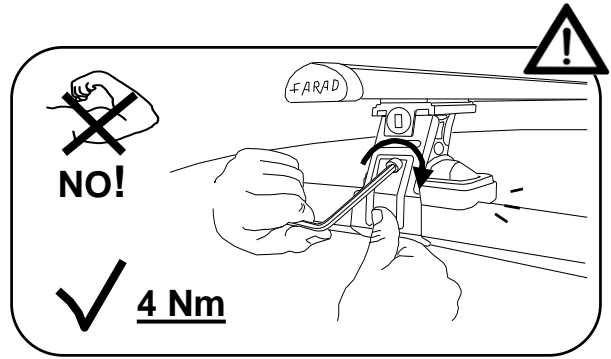
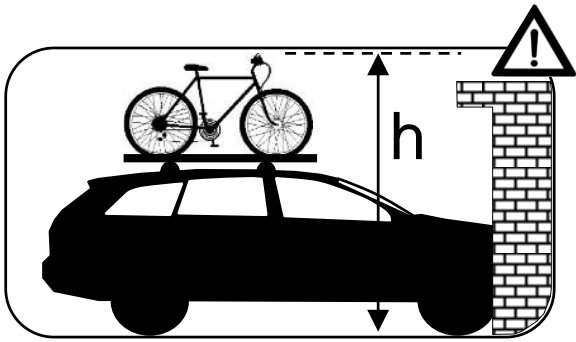

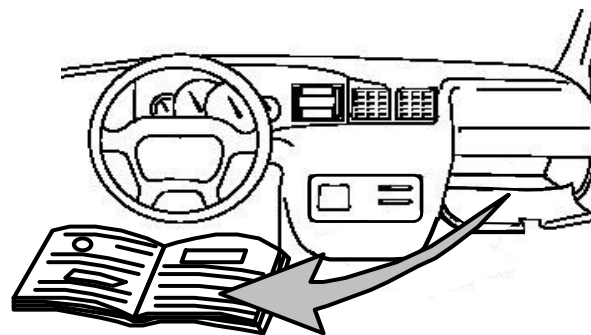
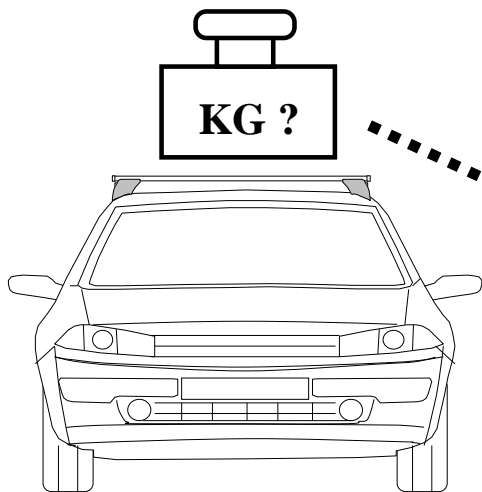

- I Controllare carico del tetto sul manuale dell'auto
- PL Sprawdz ładowność dachu w instrukcji
- GB Check roof load capacity in car instruction
- NL check de handleiding belasting van het dak van de auto
- F vérifier le chargement manuel du toit de la voiture
- D überprüfen Sie die manuelle Beladung der Autodach
- E comprobar la carga manual del techo del coche
- SWE kontrollera manuell inläggning på taket av bilen

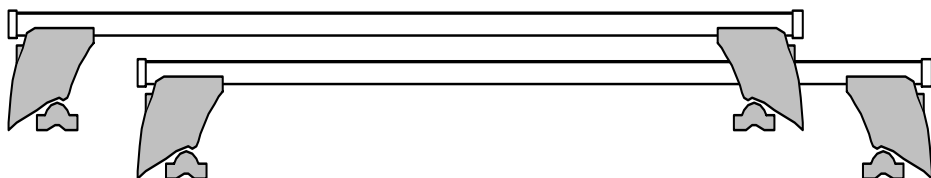
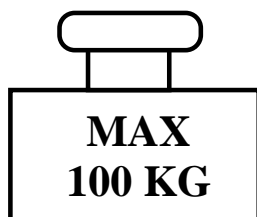
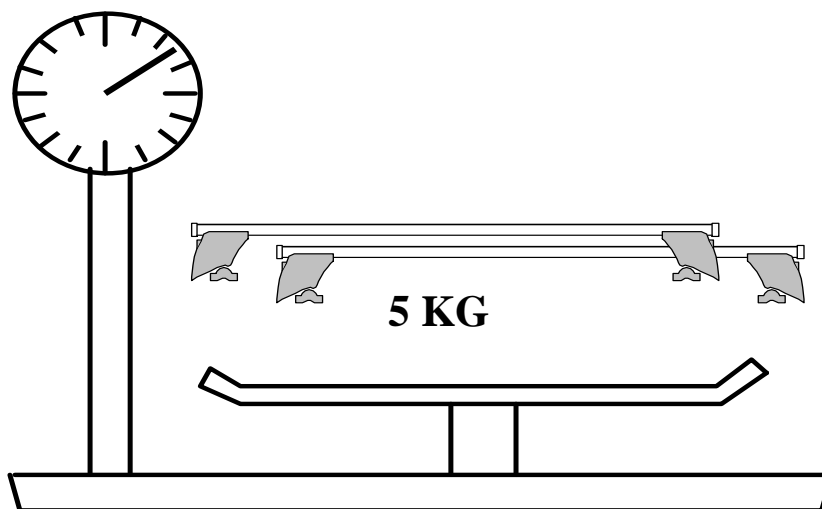

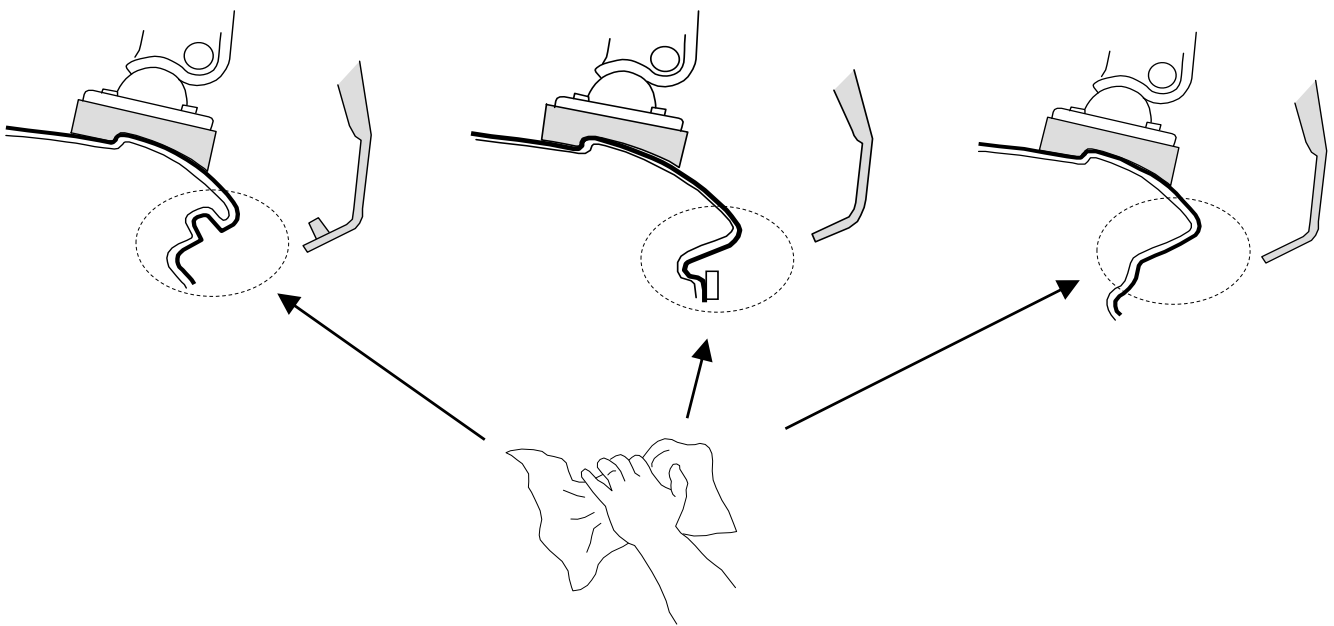
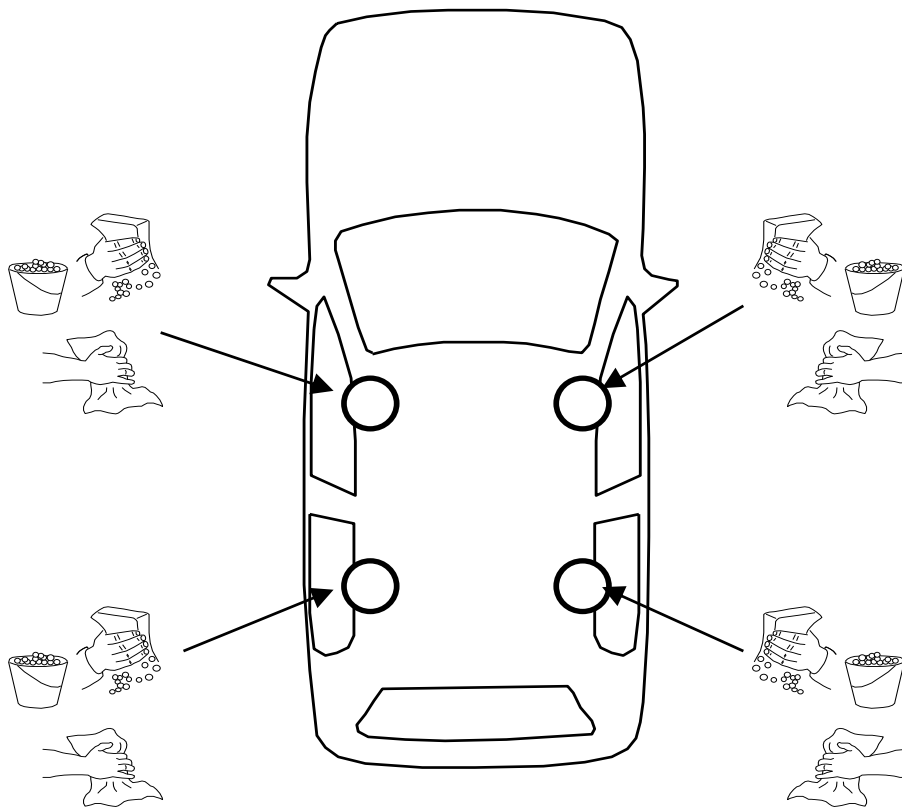

I Montaggio Barra Anteriore
PL Montaż Bagażnika Bazowego Tylnego
D Montage Vorderes Dachträgers
SWE Montering Av Främre Lasthållaren

F Fixation Barre Avant
GB Fitting Front Roof Bar
NL Montage Voorste Dakdrager
E Fijación Barra Frontal

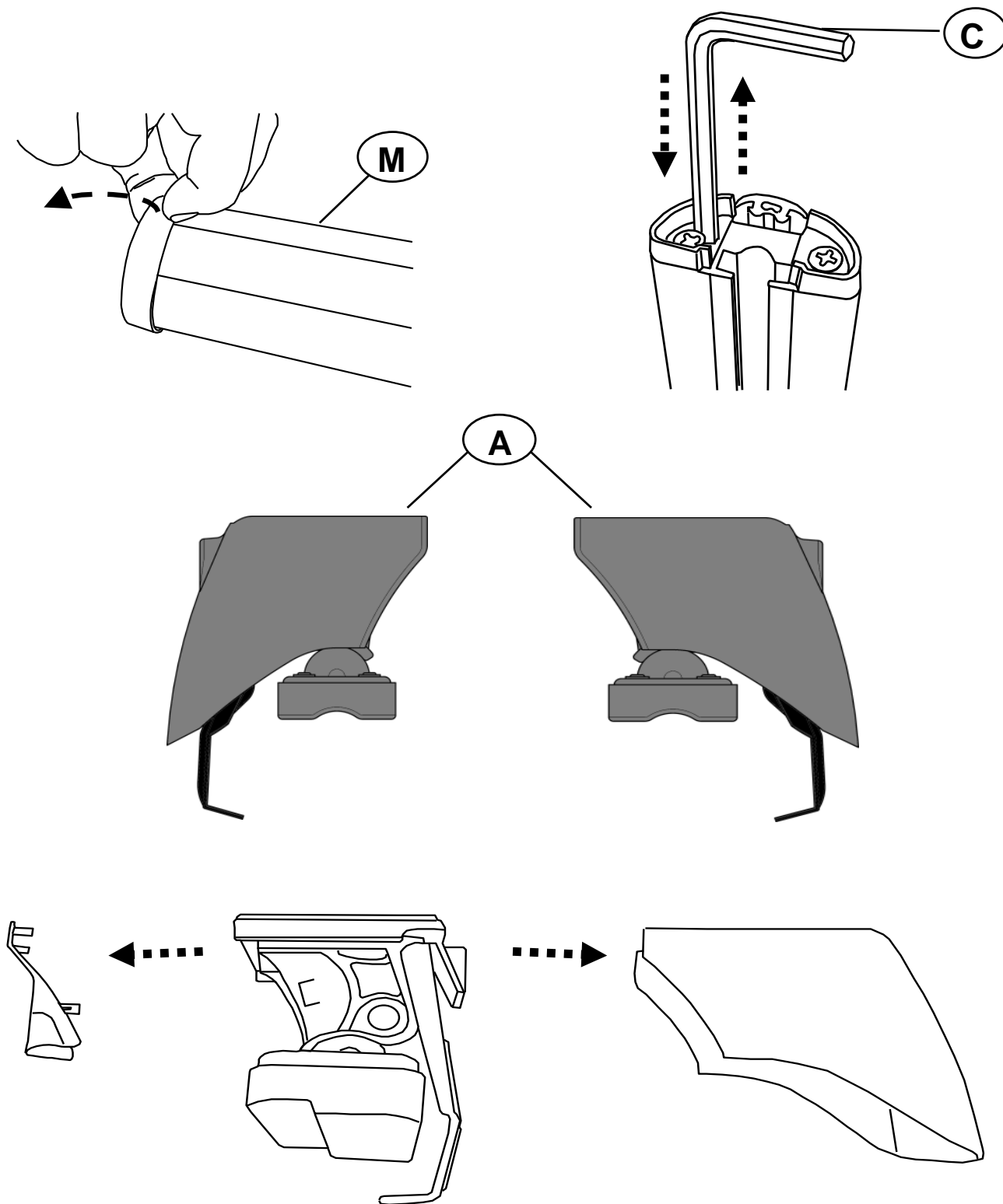



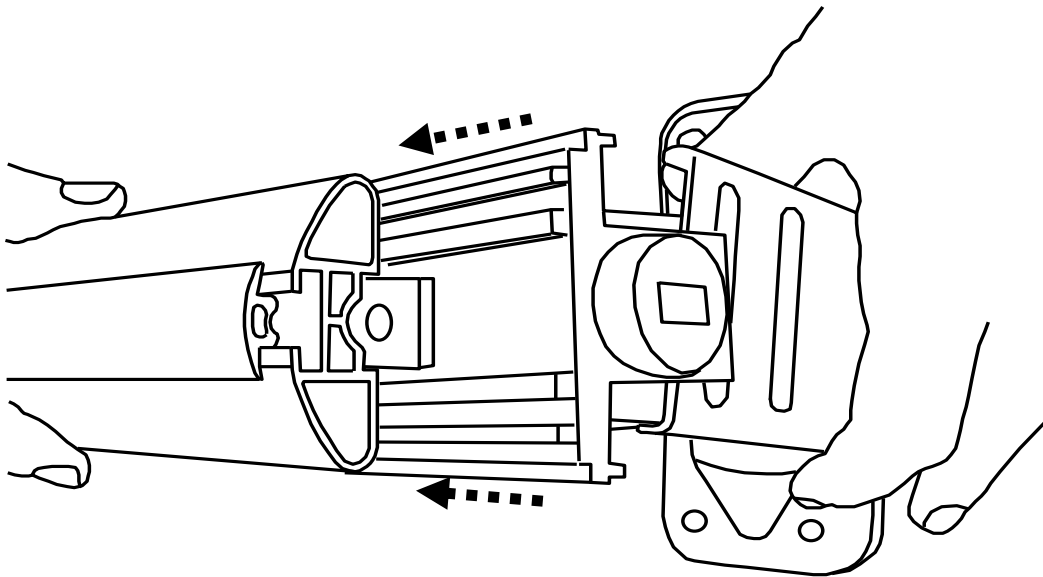
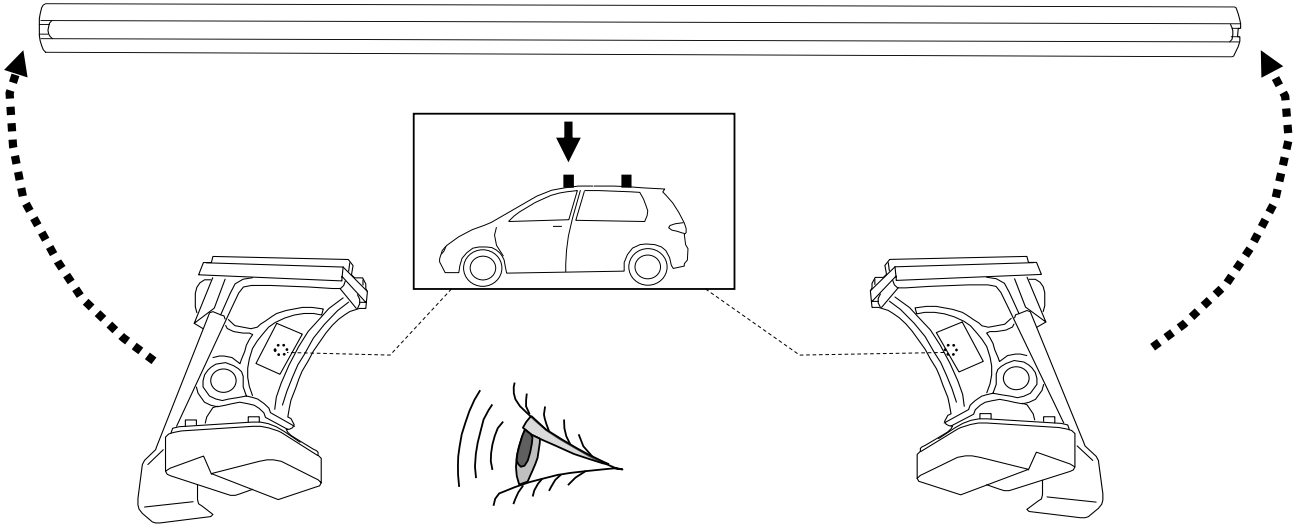

M

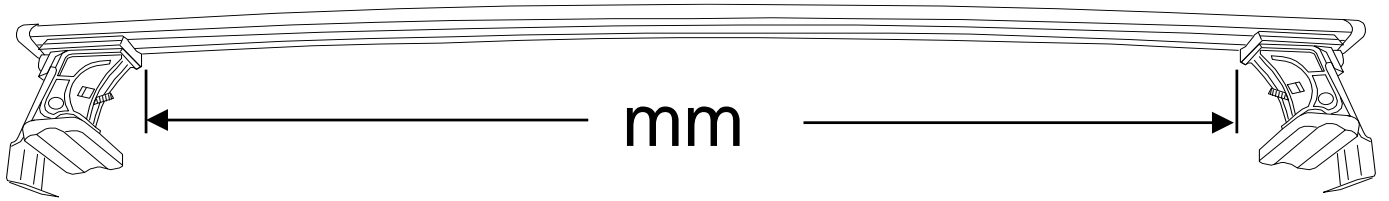



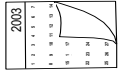

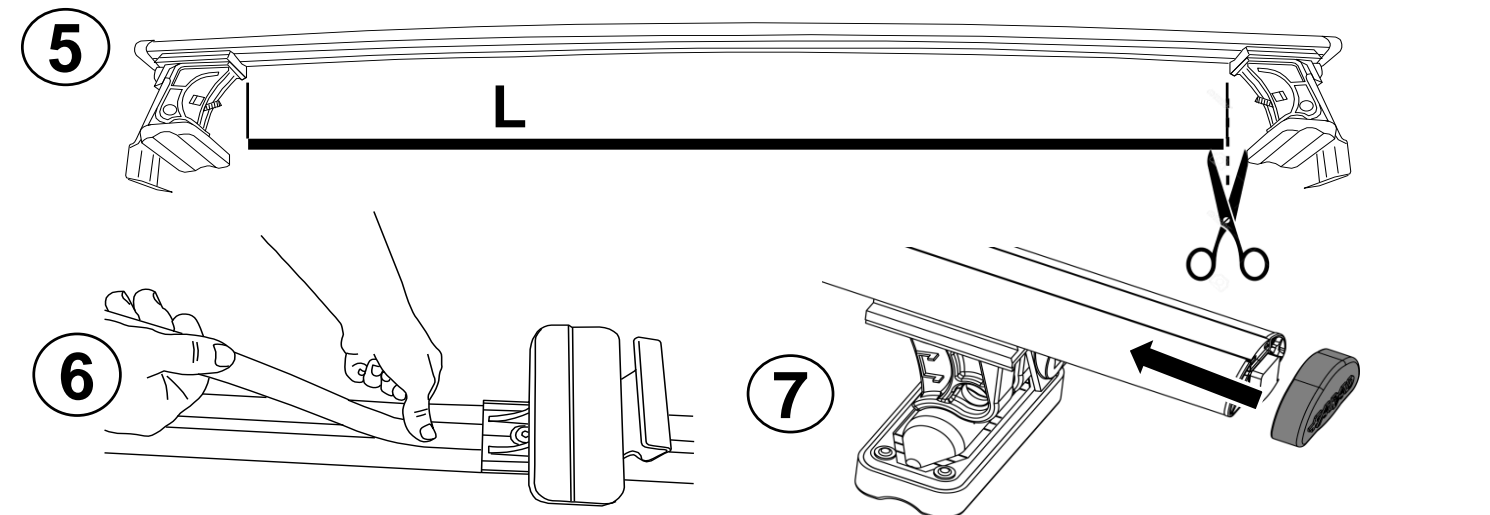
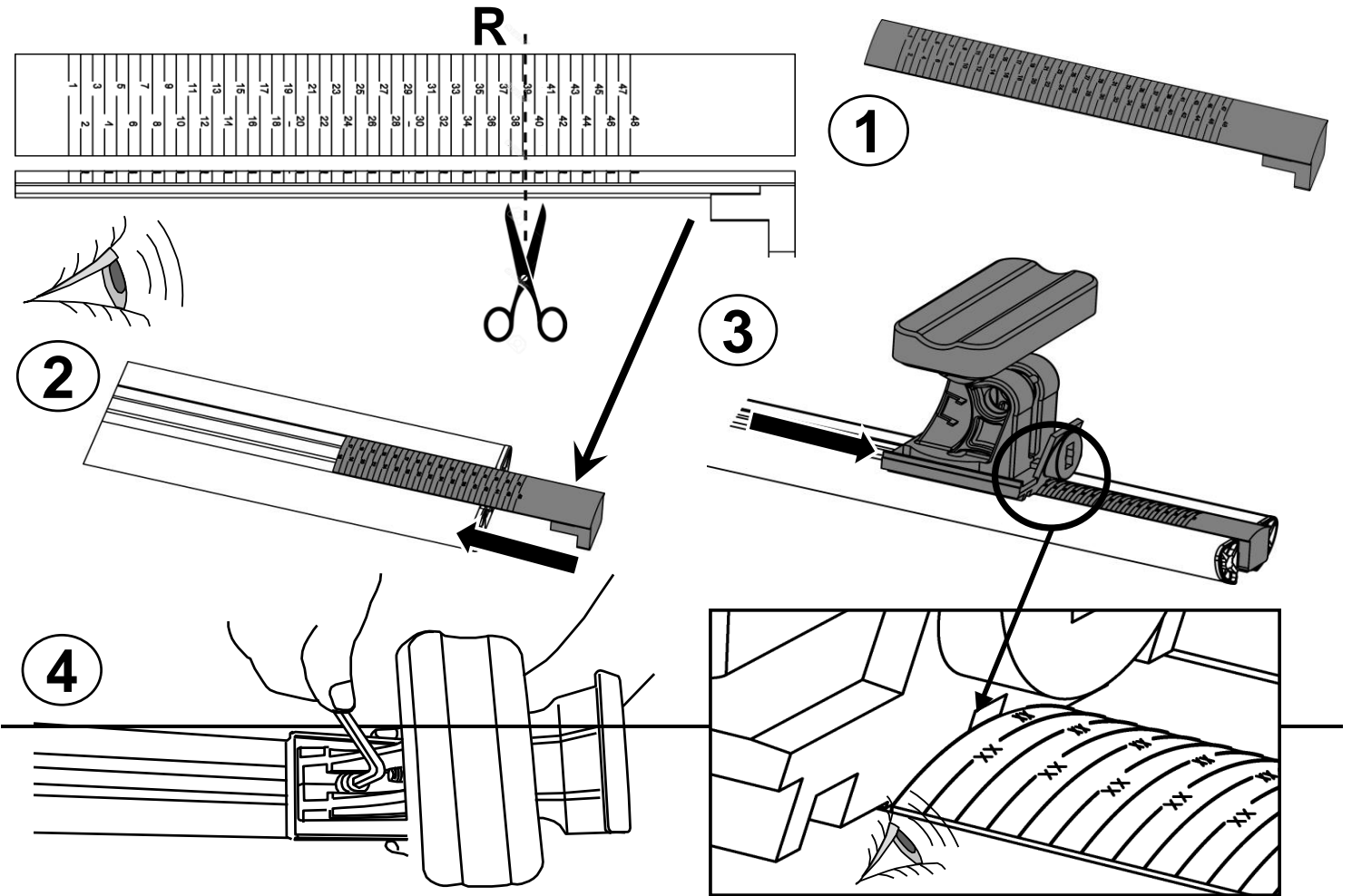
			R	mm
OPEL	KARL	5	R= 39	955

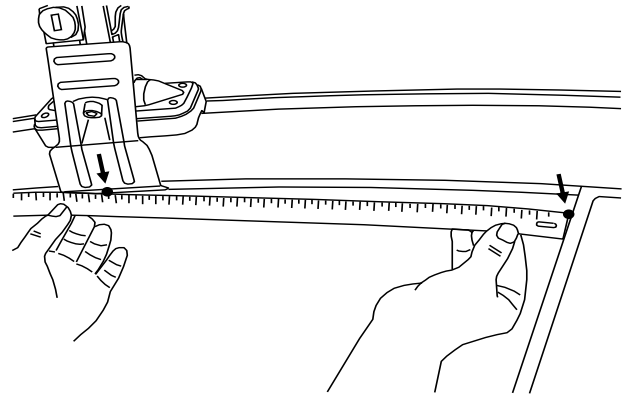
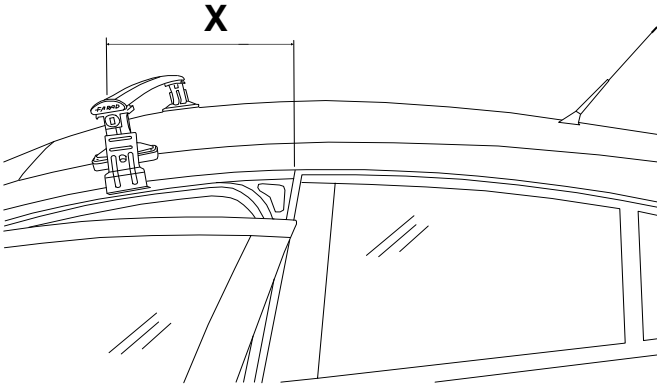
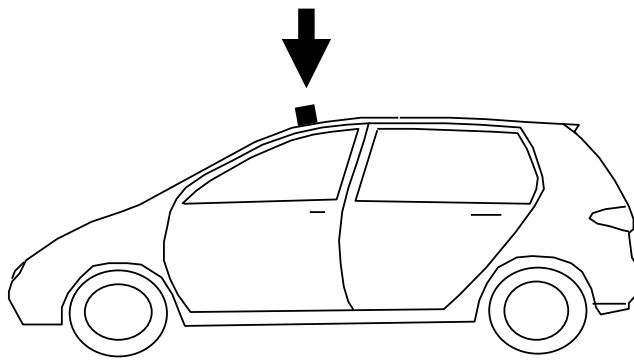

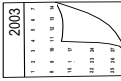

			X
OPEL	KARL	5	X= 320

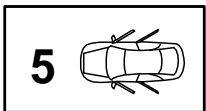

✓ 4 Nm

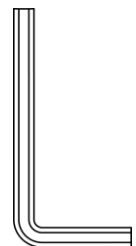
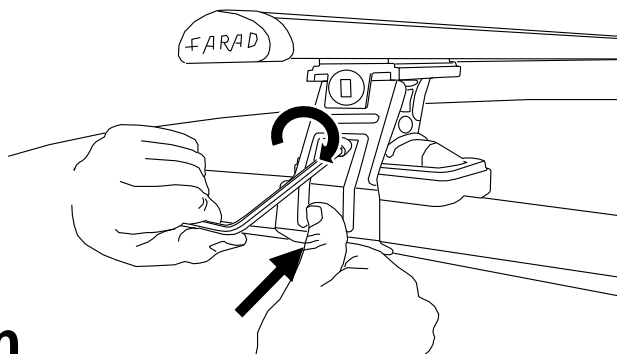

REV 000	27/03/2017	9 / 20
----------------	-------------------	---------------

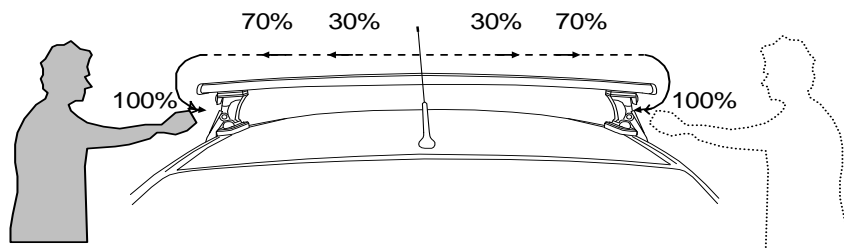

- | | | | |
|----|---|-----|------------------------------------|
| I | Alternare il fissaggio delle viti | F | Serrer alternativement chaque côté |
| PL | Śruby dokręcaj naprzemiennie | D | Die Schrauben abwechselnd anziehen |
| GB | Tighten alternately | E | Apretar alternativamente |
| NL | Afwisselend aan de linker- en de rechterkant aandraaien | SWE | Dra åt växelvis |

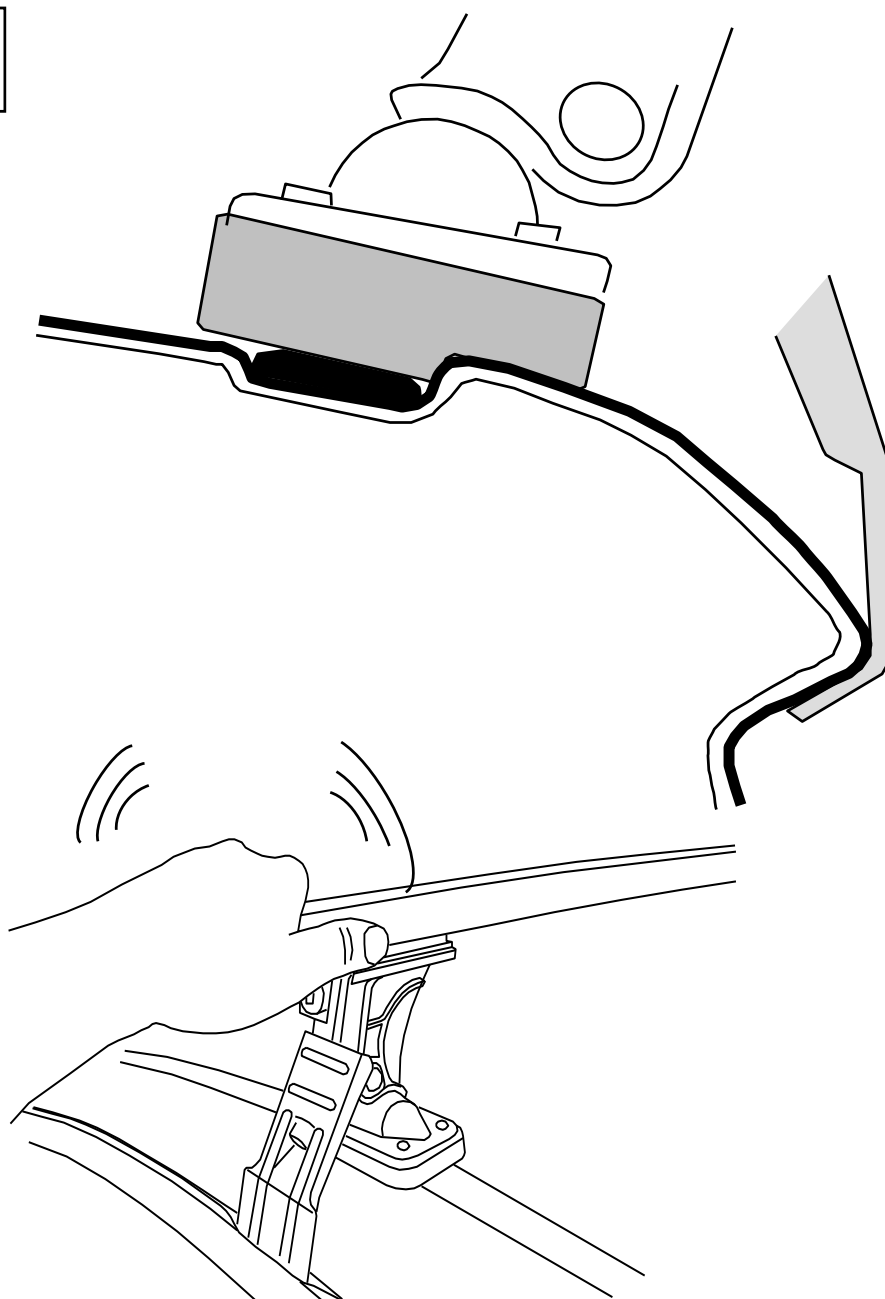
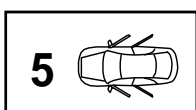

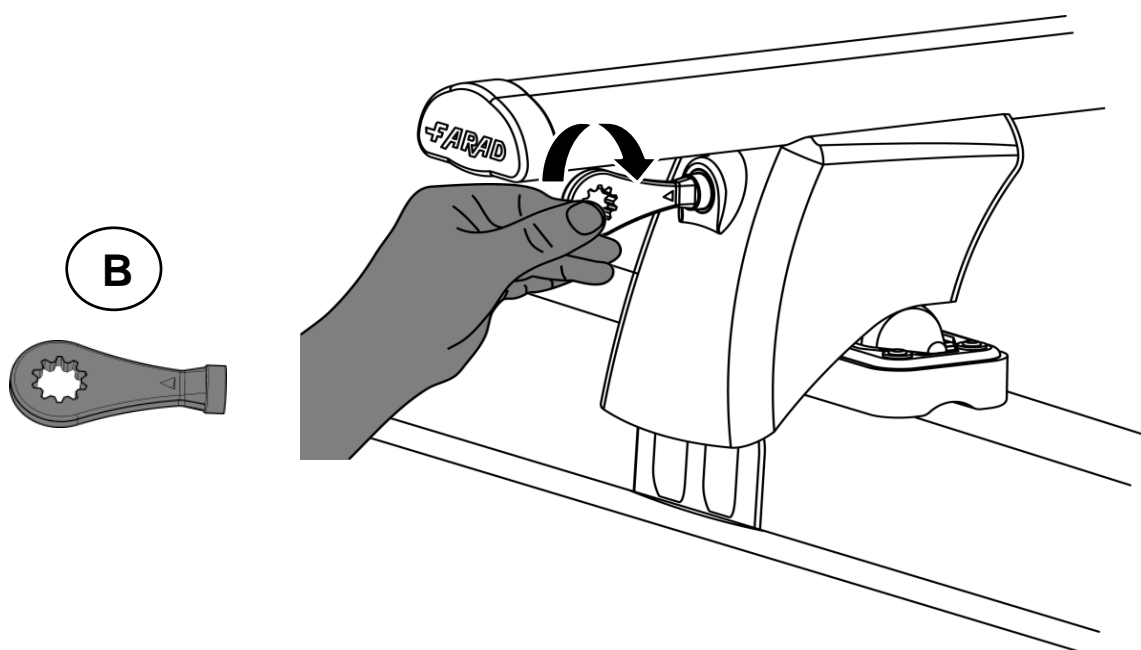
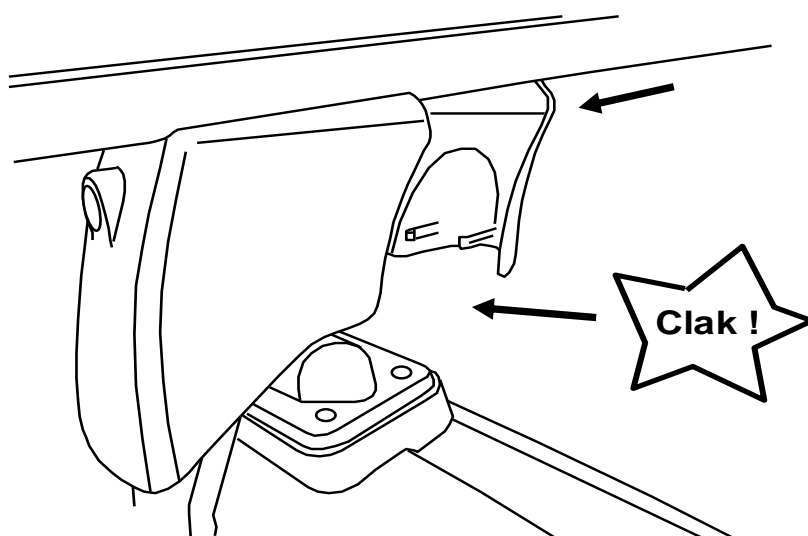
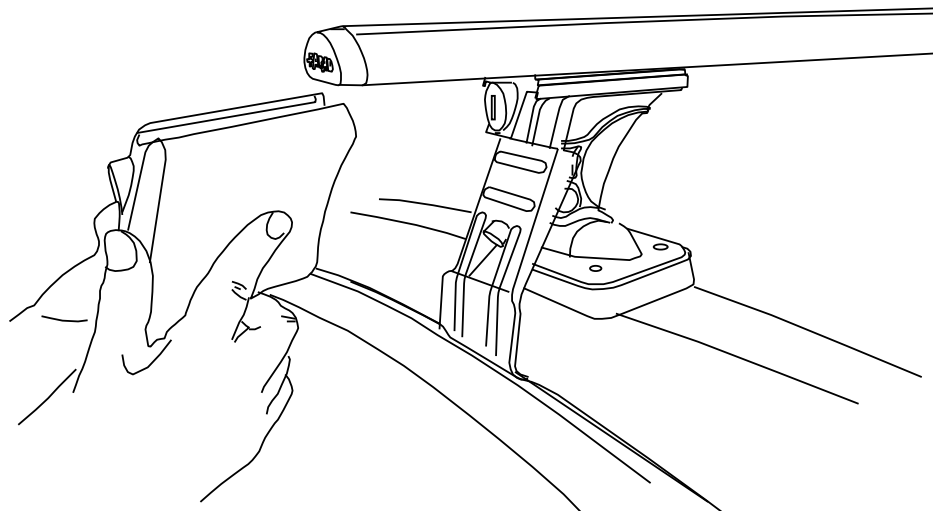

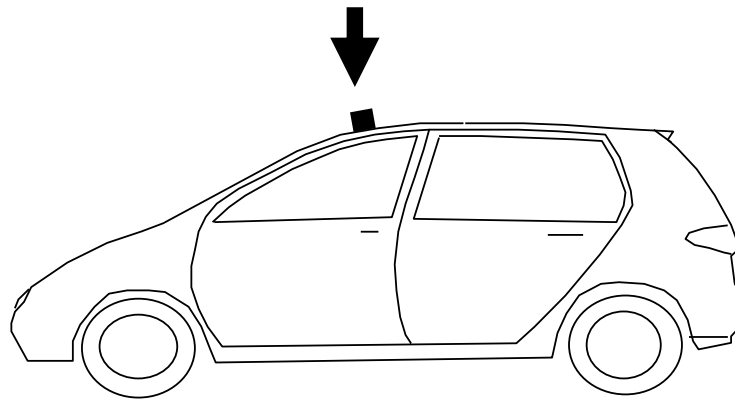

- I** CONTROLLARE PERIODICAMENTE IL FISSAGGIO DELLE VITI
- PL** OKRESOWO SPRAWDZAJ MOCOWANIE ŚRUB
- GB** CHECK THE SCREW FASTENING PERIODICALLY
- D** REGELMÄSSIG ÜBERPRÜFEN DIE BEFESTIGUNG DER SCHRAUBEN
- SWE** REGELBUNDET KONTROLLERA OM FASTSTÄLLANDE AV SKRUVARNA
- F** VERIFIEZ LA FIXATION DES VIS PERIODIQUEMENT

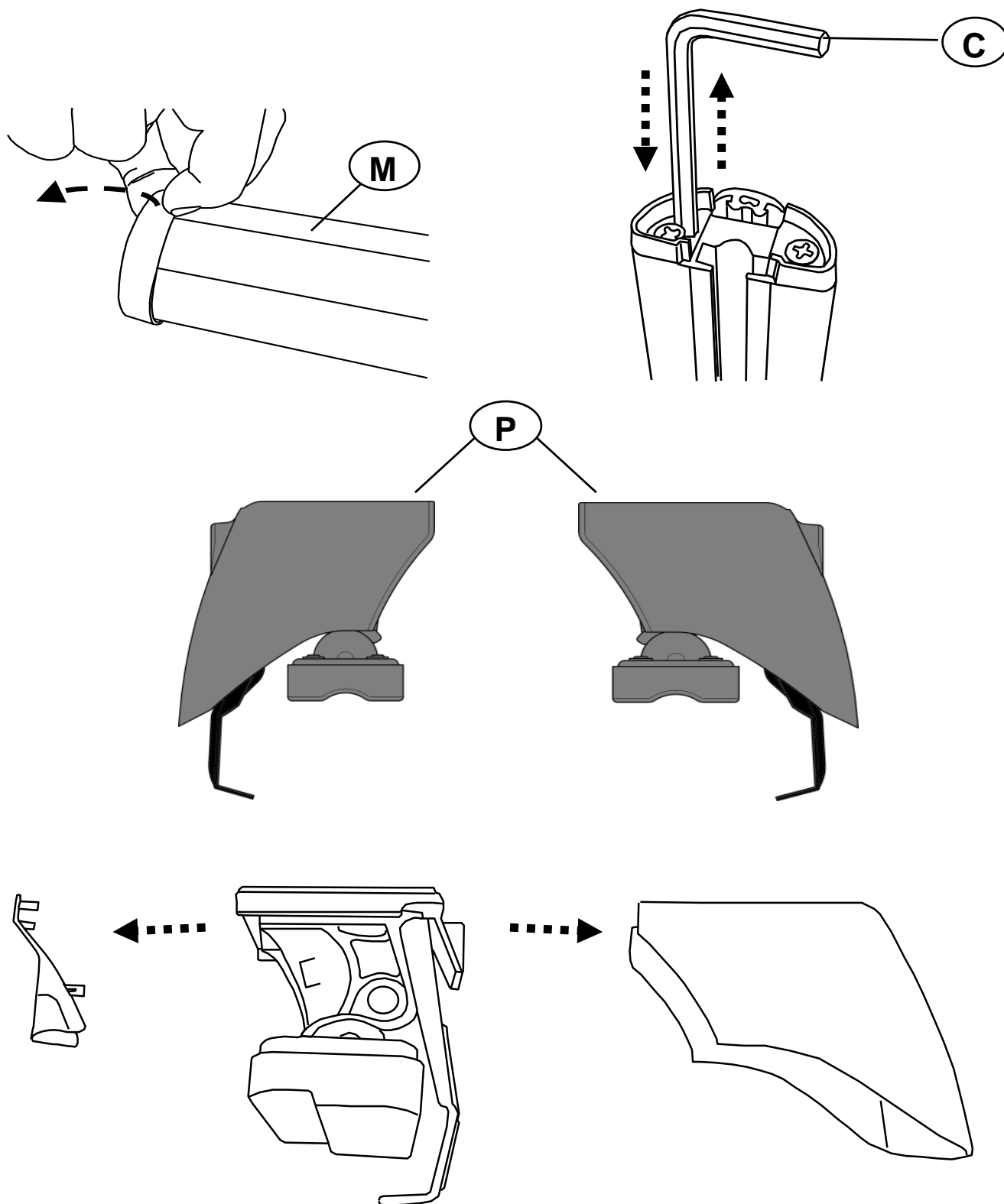

I Montaggio barra posteriore
PL Montaż Bagażnika Bazowego Przedniego
SWE Montering Främre Lasthållaren
NL Montage Achterste Dakdrager

F Fixation Barre Arriere
GB Fitting Rear Roof Bar
E Fijación Barra Trasera
D Montage Heckdachträgers

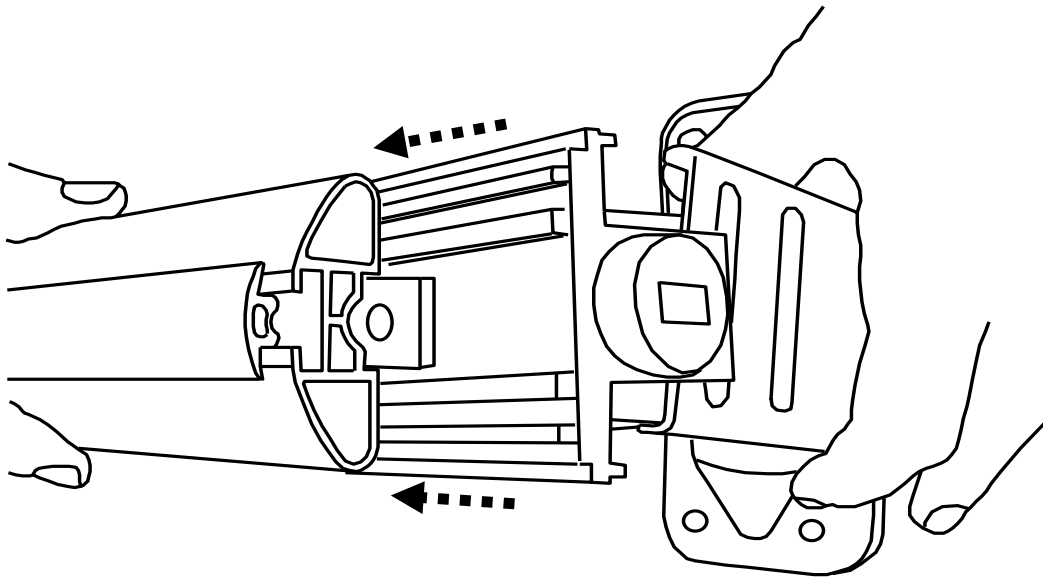
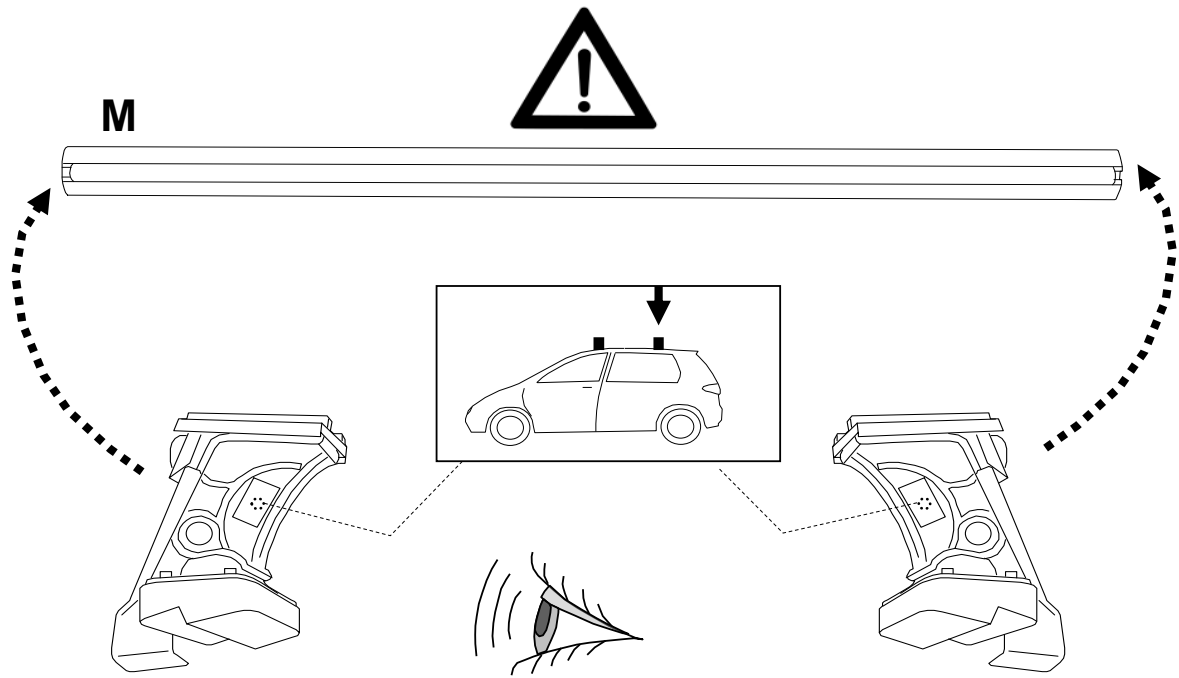

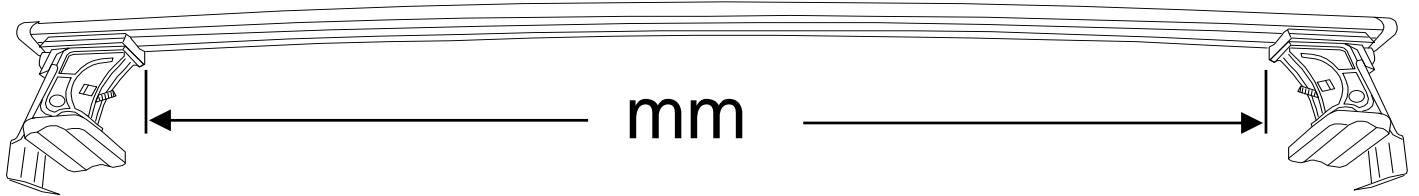





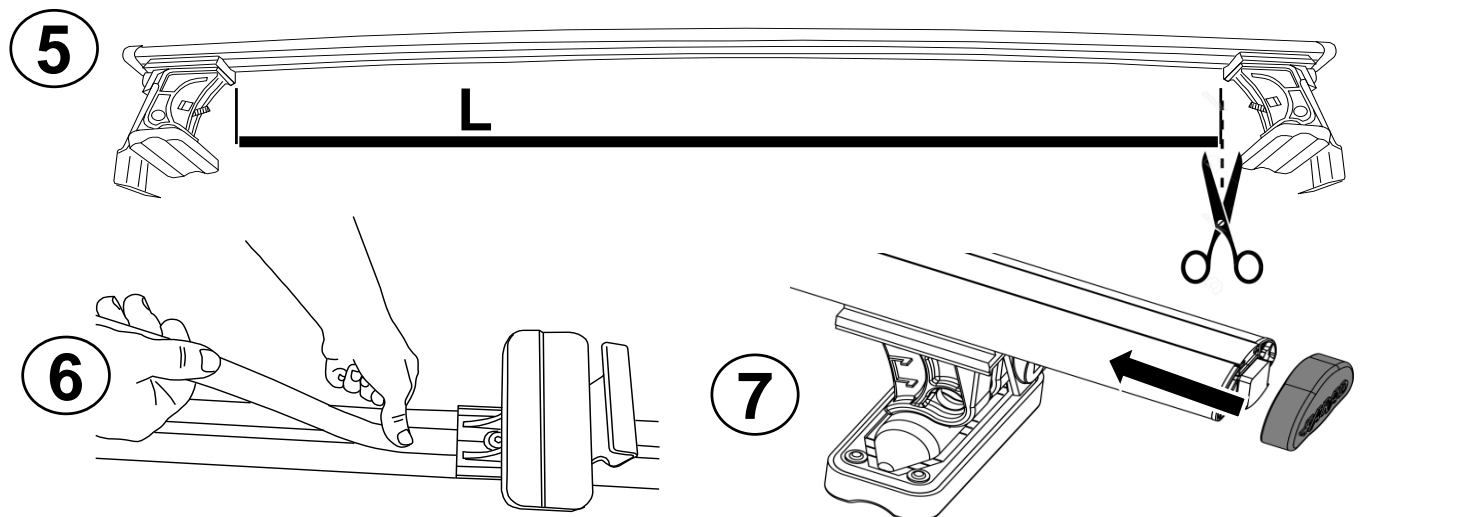
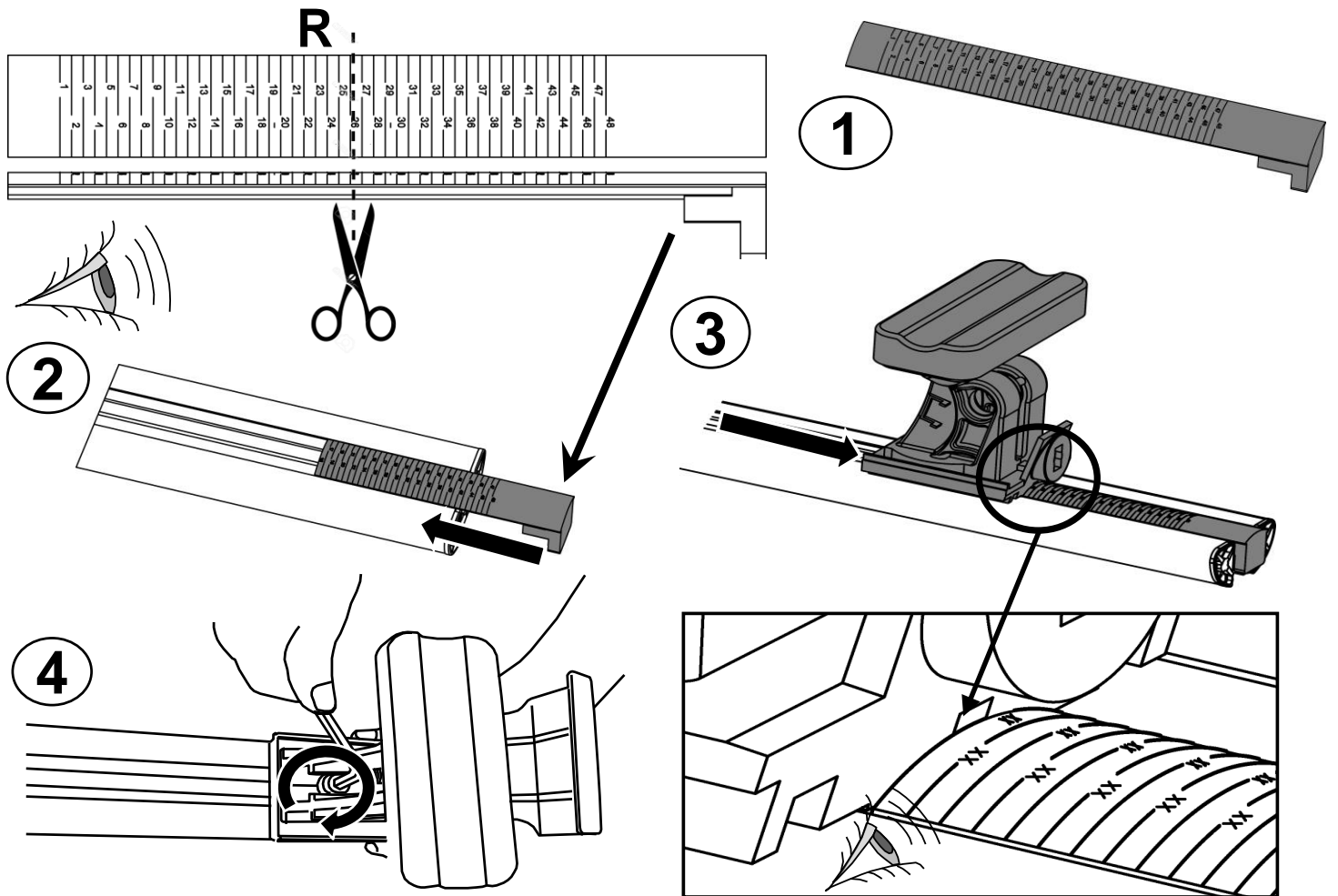

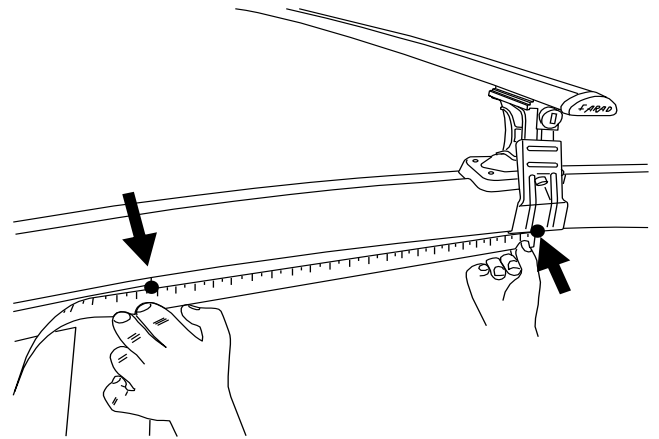
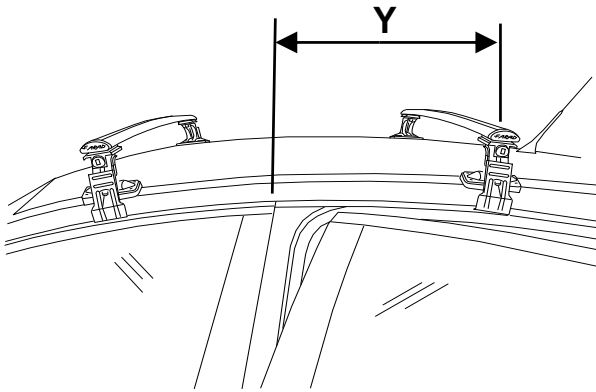
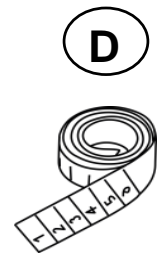
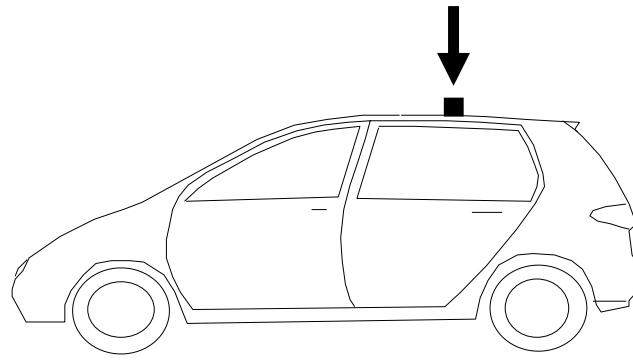
			R	mm
OPEL	KARL	5	R= 27	900



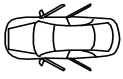

			Y
OPEL	KARL	5	Y= 350

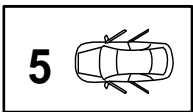

✓ **4 Nm**

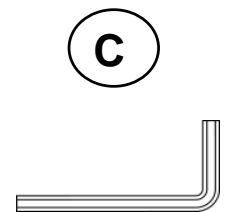
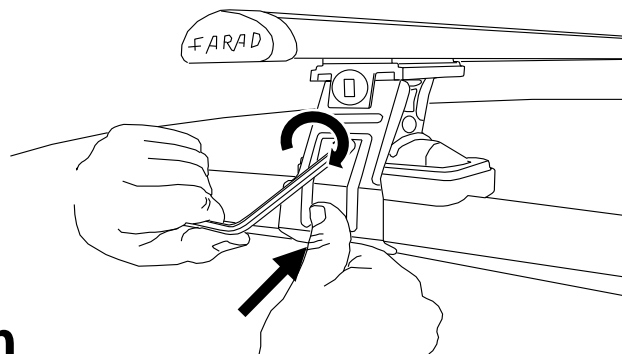

REV 000	27/03/2017	16 / 20
----------------	-------------------	----------------

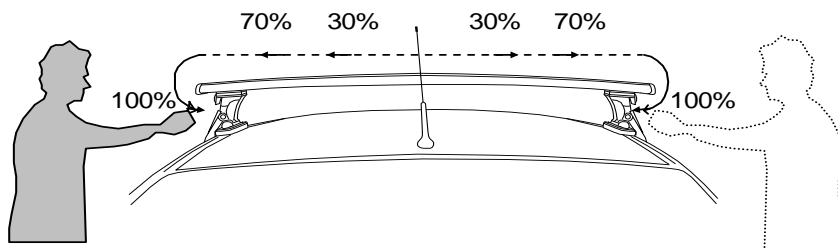

- | | | | |
|----|---|-----|------------------------------------|
| I | Alternare il fissaggio delle viti | F | Serrer alternativement chaque côté |
| PL | Śruby dokręcaj naprzemiennie | D | Die Schrauben abwechselnd anziehen |
| GB | Tighten alternately | E | Apretar alternativamente |
| NL | Afwisselend aan de linker- en de rechterkant aandraaien | SWE | Dra åt växelvis |

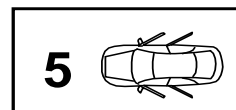
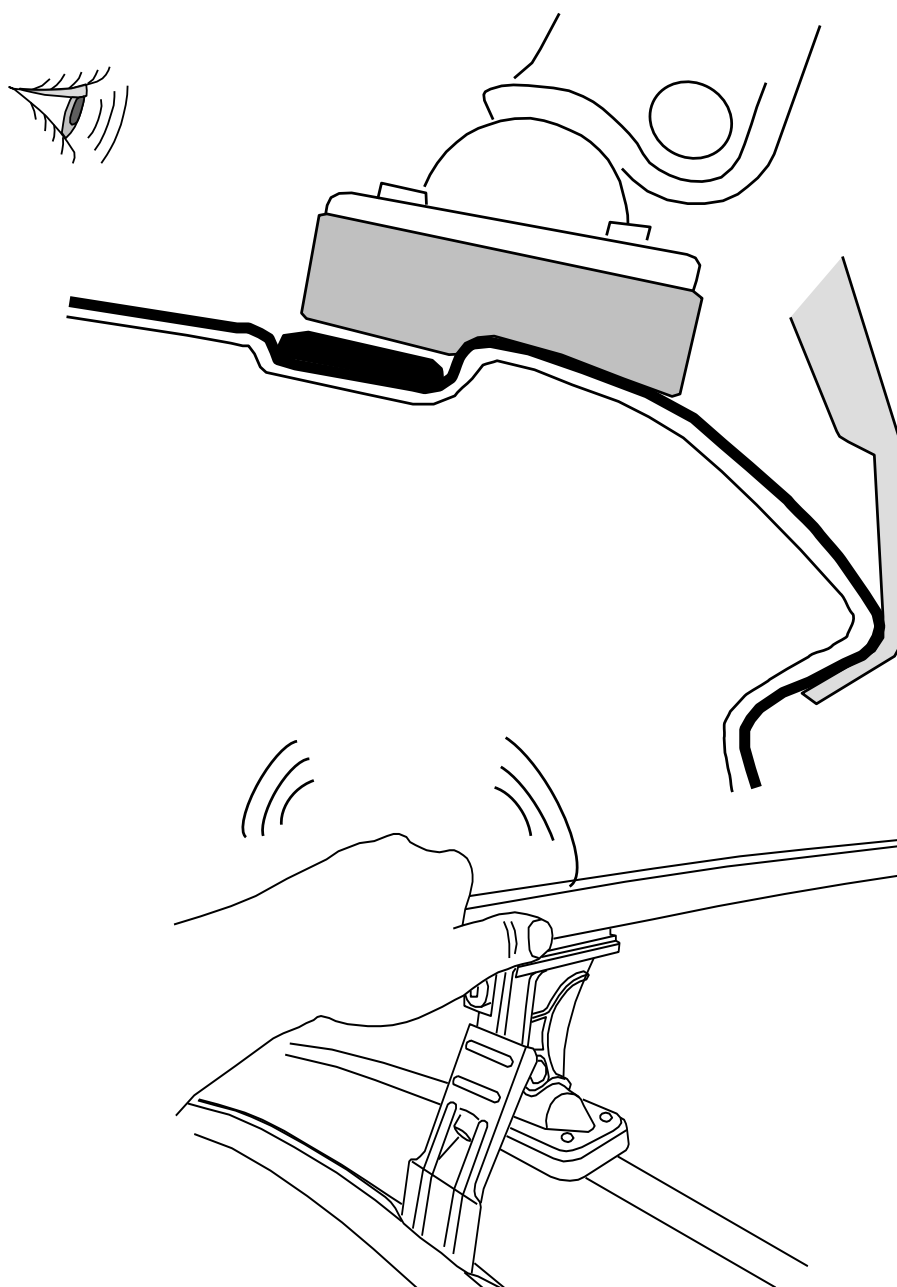

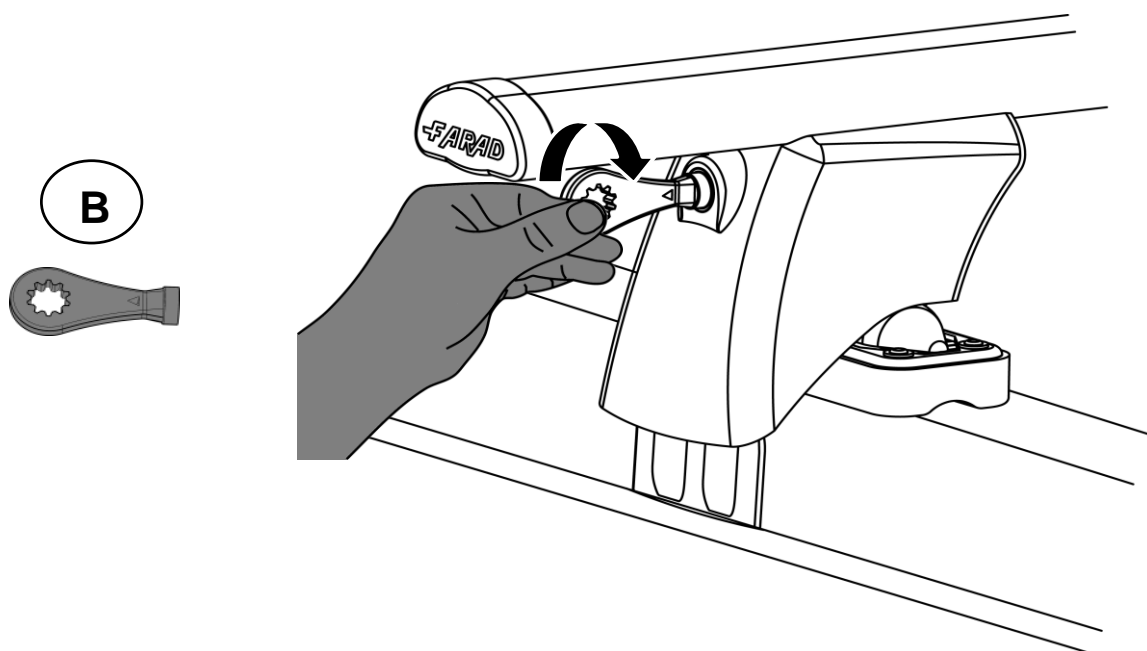
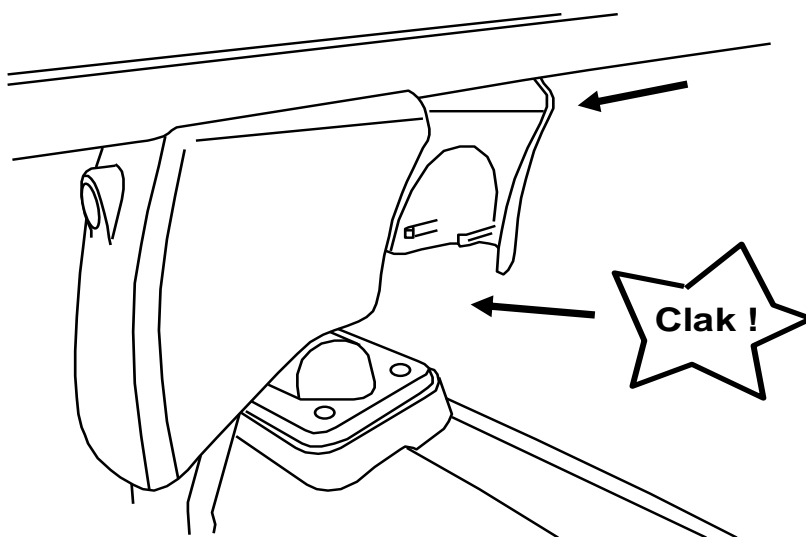
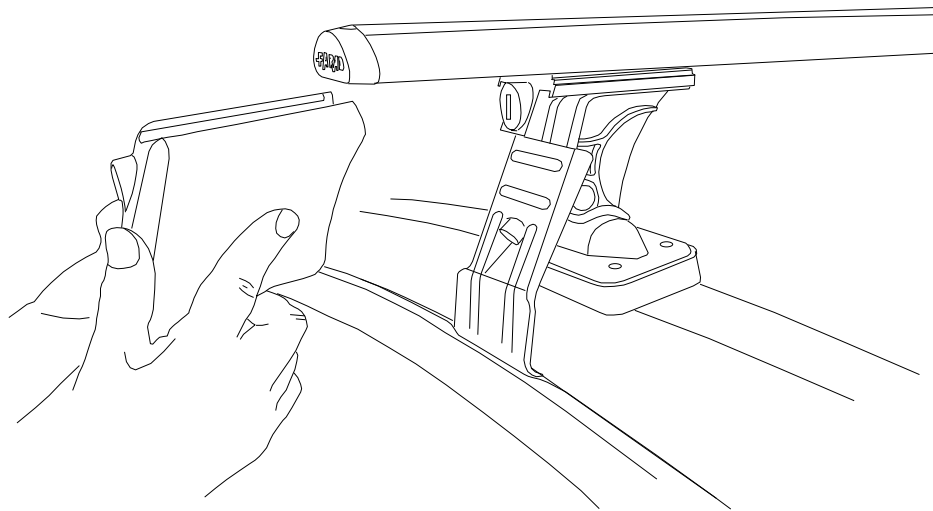

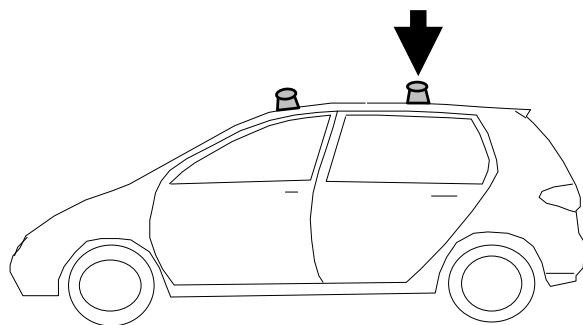

- I** CONTROLLARE PERIODICAMENTE IL FISSAGGIO DELLE VITI
- PL** OKRESOWO SPRAWDZAJ MOCOWANIE ŚRUB
- GB** CHECK THE SCREW FASTENING PERIODICALLY
- D** REGELMÄSSIG ÜBERPRÜFEN DIE BEFESTIGUNG DER SCHRAUBEN
- SWE** REGELBUNDET KONTROLLERA OM FASTSTÄLLANDE AV SKRUVARNA
- F** VERIFIEZ LA FIXATION DES VIS PERIODIQUEMENT

RICAMBI - SPARE PARTS



PIEDE GIREVOLE
90341 / 2

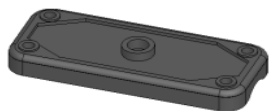

PIEDE FISSO
90341 / 15

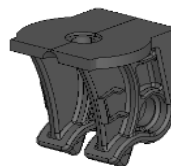

SUPPORTO CENTRALE
90341 / 1

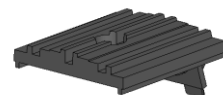

SUPPORTO BARRA
90341 / 5



SOTTO PIEDE SP01
90341 / 3



SOTTO PIEDE SP03
90341 / 16



SOTTO PIEDE SP04
90341 / 13

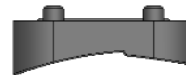

SOTTO PIEDE SP07
90341 / 11



SOTTO PIEDE SP08
90341/14



SOTTO PIEDE SP10
90341 / 12



SOTTO PIEDE SP12
90341 / 1



CHIAVE ESAGONALE 6
9331 / 148

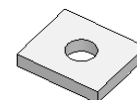

PIASTRINA
90341 / 21



DISTANZIALE
90341 / 20



NOTTOLINO + N° COMB.
90341 / 6



SOTTOTAPPO
90241 / 9



TAPPO BARRA
90241 / 6

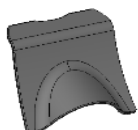

INVOLUCRO POST.
90341 / 9

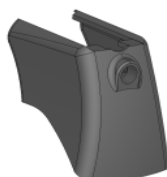

INVOLUCRO ANTERIORE
90341 / 8



CHIAVE + N° COMB
90341 / 7

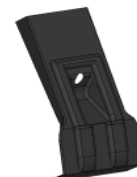

PALETTA
90341 / 4



BARRA ALLUMINIO
90241 / 7



GUARNIZIONE BARRA
90241 / 8



RIGA CARTA
90341 / 19

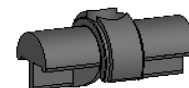

PERNO
90241 / 15

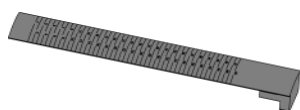

GUARNIZIONE
NUMERICA
91141 / 14

FARAD[®]
made in italy

tel. 011 9713719 - n° verde 800984229
www.faradworld.com